

Series OU

Ultramini – clever – reliability in confined quarters

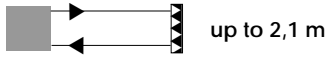

Through-beam sensors OUS/OUE



Retro-reflective sensors OUR

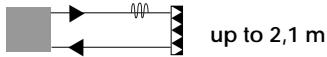

Retro-reflective sensors
with polarizing filters OUP and OUC



Diffuse-reflective sensors OUT



High functionality

Diverse operating principles

ELESTA's OU sensors are available as through-beam sensors, retro-reflective sensors with and without polarizing filters, retro-reflective sensors for transparent objects, as well as diffuse-reflective sensors.

Light reserve warning indicator

All of the sensors in the OU series contain a *light-reserve warning indicator* (blinking function indicator) for controlling dirt build-up on the lenses and as an *alignment aid*.

High switching frequency

All OU sensors have a 1000 Hz switching frequency, allowing for the reliable detection of even fast moving objects.

Low power consumption

The OU sensors distinguish themselves with an extremely small power consumption of less than 15 mA.

Test input

The OU through-beam sensors are available standard with *test input*, for confirming that the sensor is operating properly.

Simple installation and operation

Adjustable range

The optical range of the diffuse-reflective OU sensors can be adjusted to meet the specific application.

Various connection versions

All OU sensors are available standard with a 4 wire 2 m cable or a 4 pin M8 connector (snap-on or threaded).

Clever mounting concept

In contrast to the side mounting of traditional sensors, the OU mini-sensor from Elesta is designed for front or back mounting in the direction of the optical axis with only 10 mm depth. Thanks to recessed screws or nuts, a clean flush mounting is possible with no protruding parts. With two M3 screws and metal reinforced mounting holes, this mini-sensor can be fastened everywhere, simply and reliably.



Reliable for the highest demands

Robust construction with IP 67 sealing

The OU photoelectric sensors are built with a robust polycarbonate housing, and are protected against water and dust. The sensors meet the *sealing* requirements of IP 67.

EMC-tested

The OU sensors are tested according to IEC 801, EN50081-1 and EN50082-2. This assures trouble free use even in high electromagnetically contaminated environments.

High ambient light rejection

Thanks to pulse modulation and a very sensitive ambient light suppression with active disturbing light recognition and rejection, the OU sensors are extremely insensitive to foreign light sources e.g. HF-lamps, etc.

«Crosstalk» suppression

Through the active «crosstalk» suppression, the OU sensors function reliably even when oppositely mounted.

Reverse polarity protection

All of the OU sensor's electrical connections are protected against reverse wiring.

Short-circuit protection

The OU sensor's transistor outputs are electronically protected against short circuit.

Power-up output suppression

During power-up the outputs of the OU sensors are blocked for typically 90 msec.

Designation code

OU X XXX XXX XX

| Principle | Supply | Outputs | Connection | Electr. option | Light | Range |
|---|--------------|---|---------------------------------|--|-----------------------|---|
| C: Retro-reflective for transparent objects E: Through-beam receiver P: Retro-reflective with polarizing filters R: Retro-reflective S: Through-beam emitter T: Diffuse-reflective Z: Accessory | 1: 10-30 VDC | KA: No output NA: NPN <i>light- and dark-on</i> PA: PNP <i>light- and dark-on</i> | 1: Cable 2 m 5: Connector M8 | 00: Range adjustable 01: Range adjustable, <i>test input</i> 40: Range not adjustable 41: Range not adjustable, <i>test input</i> | I: infrared R: red | OUS/OUE: 1: 4 m OUR/OUP/OUC: 1: 1 m 2: 0,8 m OUT: 1: 5 cm 2: 10 cm |

Accessories

Retroreflectors: see page 130

Connector cables: see page 128

Through-beam sensors, ultramini



- Front or back mounting in the direction of the optical axis
- *Light reserve warning indicator*
- Insensitive to foreign light sources, e.g. HF-lamps, etc.
- Dual transistor outputs, NPN or PNP
- *Short-circuit protection, reverse polarity protection, and power-up output suppression*
- *Test input*
- Connections: Cable, 2 meter
Connector, M8
- EMC tested according to IEC 801 and EN50081-1/EN 50082-2



Product designation¹⁾

| |
|------------------|
| Output |
| Connection |
| Range adjustment |

Optical data²⁾

| |
|------------|
| Max. range |
| Emitter |

Electrical data²⁾

| |
|--|
| Supply voltage U_s |
| Allowable ripple |
| Current consumption (without load) |
| Max. load current I_L |
| Residual voltage |
| Max. switching frequency |
| <i>Test input:</i> emitter on emitter off |

Environmental data

| |
|--|
| Sealing |
| Temperature T_A (operating and storage) |
| Weight |

| Emitter | | Receiver | | | |
|----------------------------------|-------------------|--------------------------|-------------------|--------------------------|-------------------|
| OUS 1KA 141 R1 | OUS 1KA 541 R1 | OUE 1NA 140 R1 | OUE 1NA 540 R1 | OUE 1PA 140 R1 | OUE 1PA 540 R1 |
| | | NPN (light- and dark-on) | | PNP (light- and dark-on) | |
| Cable 2 m | Connector M8 | Cable 2 m | Connector M8 | Cable 2 m | Connector M8 |
| No | | No | | | |
| 4 m | | | | | |
| Red-LED, 650 nm, pulsed | | | | | |
| 10...30 VDC | | | | | |
| +/- 10% of U_s | | | | | |
| < 15 mA | | < 8 mA | | | |
| | | 100 mA | | | |
| | | < 1,6 V | | | |
| | | 1000 Hz | | | |
| $\geq 7 V$ open or $\leq 3 V$ | | | | | |
| IP 67 | | | | | |
| -25...+65 °C | | | | | |
| ca. 45 g | ca. 4 g | ca. 45 g | ca. 4 g | ca. 45 g | ca. 4 g |

1) For product designation of sensors with options see designation code on page 13.

2) When not otherwise noted, all technical data at $T_A = 25^\circ\text{C}$ and $U_s = 24 V$.

Note:

The emitter is only activated, if the *test input* is connected to U_s or to a corresponding test signal.

10...30 VDC

NPN / PNP
light-on and
dark-on output

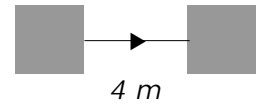

OUS/OUE

Dimensions (30 mm x 10 mm x 14 mm)

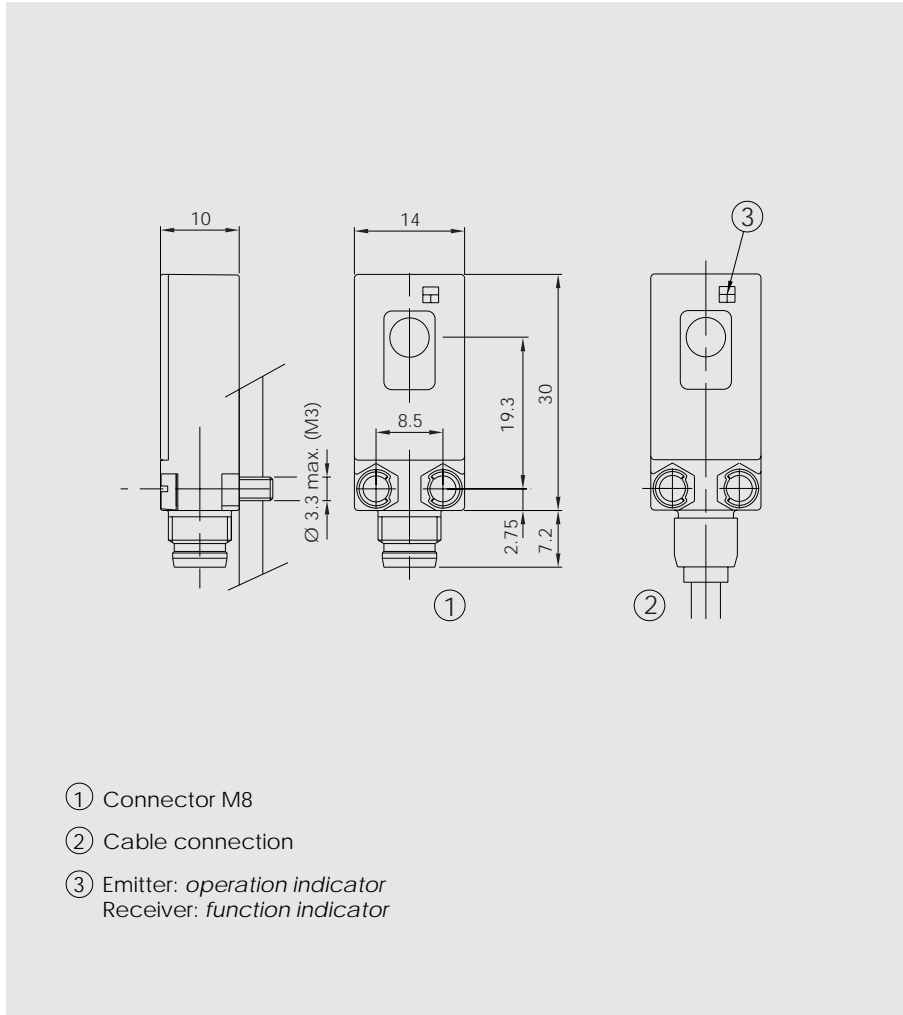

Optical diagrams

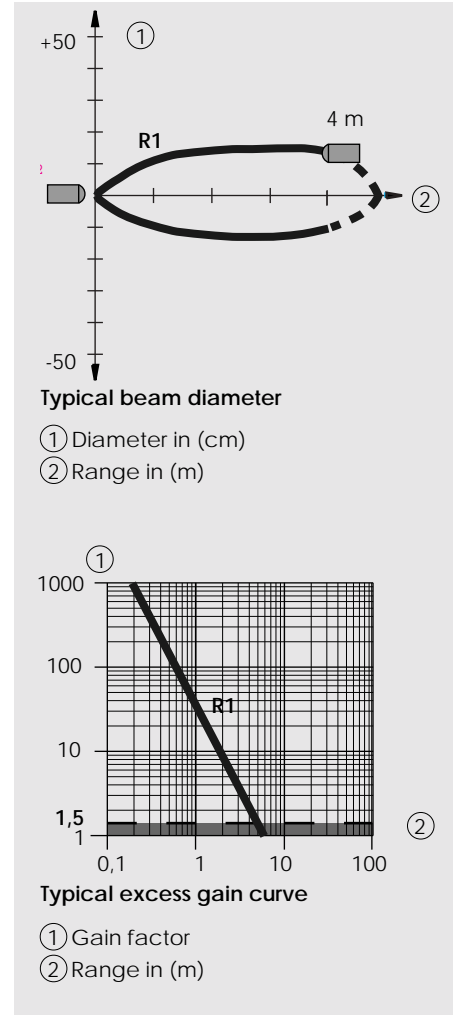

Wiring diagram

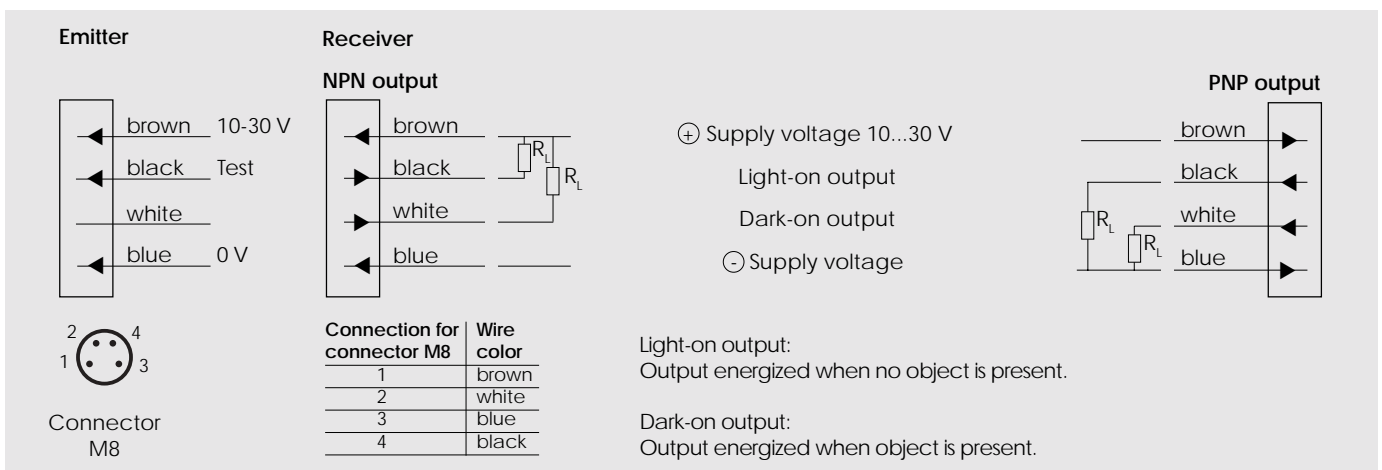

Retro-reflective sensors, ultramini



- Front or back mounting in the direction of the optical axis
- Light reserve warning indicator
- Insensitive to foreign light sources, e.g. HF-lamps, etc.
- «Cross-talk» suppression for elimination of mutual disturbances
- Dual transistor outputs, NPN or PNP
- Short-circuit protection, reverse polarity protection, and power-up output suppression
- Connections: Cable, 2 meter
Connector, M8
- EMC tested according to IEC 801 and EN50081-1/EN 50082-2



Product designation¹⁾

| |
|--|
| Output |
| Connection |
| Range adjustment |
| Optical data ²⁾ |
| Range |
| Emitter |
| Electrical data ²⁾ |
| Supply voltage U_s |
| Allowable ripple |
| Current consumption (without load) |
| Max. load current I_L |
| Residual voltage |
| Max. switching frequency |
| Environmental data |
| Sealing |
| Temperature T_A (operating and storage) |
| Weight |

| OUR 1NA 140 I1 | OUR 1NA 540 I1 | OUR 1PA 140 I1 | OUR 1PA 540 I1 |
|-------------------------------------|-------------------|--------------------------|-------------------|
| NPN (light- and dark-on) | | PNP (light- and dark-on) | |
| Cable 2 m | Connector M8 | Cable 2 m | Connector M8 |
| No | | | |
| 0,03...1 m (retroreflector OZR 001) | | | |
| Infrared-LED, 870 nm, pulsed | | | |
| 10...30 VDC | | | |
| +/- 10% of U_s | | | |
| < 15 mA | | | |
| 100 mA | | | |
| < 1,6 V | | | |
| 1000 Hz | | | |
| IP 67 | | | |
| -25...+65 °C | | | |
| ca. 45 g | ca. 4 g | ca. 45 g | ca. 4 g |

1) For product designation of sensors with options see designation code on page 13.

2) When not otherwise noted, all technical data at $T_A = 25\text{ °C}$ and $U_s = 24\text{ V}$.

| Retro-reflector ● | Range | Retro-reflector ■ | Range | Retro-reflective tape | Range |
|-------------------|---------------|-------------------|--------------|-----------------------|---------------|
| OZR 001 | 0.03 – 1.0 m | OZR 101 | 0.03 – 1.6 m | OZR 201* | 0.08 – 0.3 m |
| OZR 002 | 0.02 – 0.9 m | OZR 102 | 0.03 – 0.5 m | OZR 202 | 0.10 – 0.9 m |
| OZR 003 | 0.02 – 0.35 m | OZR 103 | 0.03 – 1.2 m | OZR 203 | 0.10 – 0.6 m |
| | | OZR 104 | 0.03 – 2.1 m | OZR 204* | 0.10 – 0.45 m |
| | | | | OZR 205* | 0.10 – 0.55 m |

* 30 cm long

10...30 VDC

NPN / PNP
light-on and
dark-on output

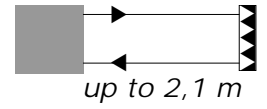

OUR

Dimensions (30 mm x 10 mm x 14 mm)

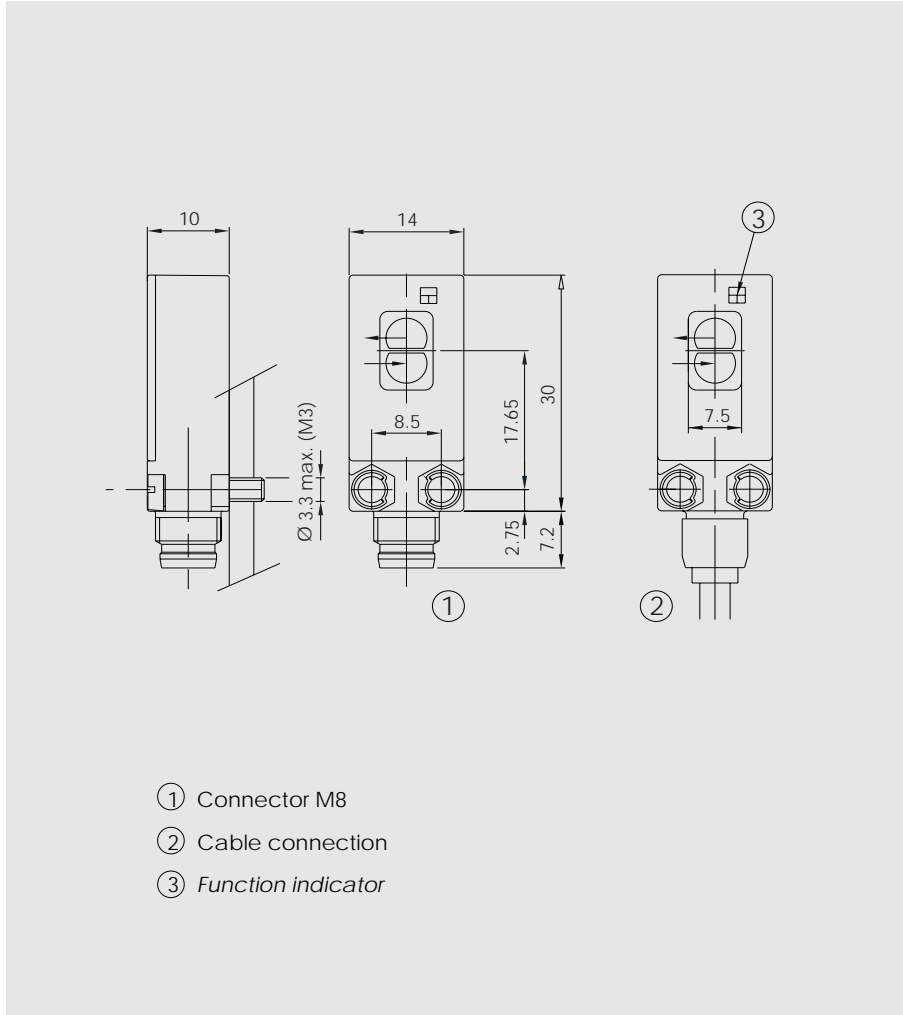

Optical diagrams

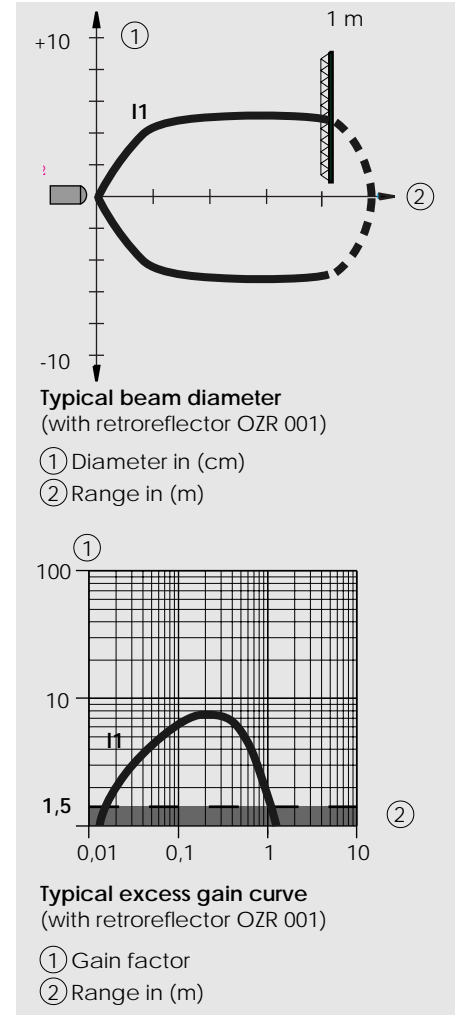

Wiring diagram

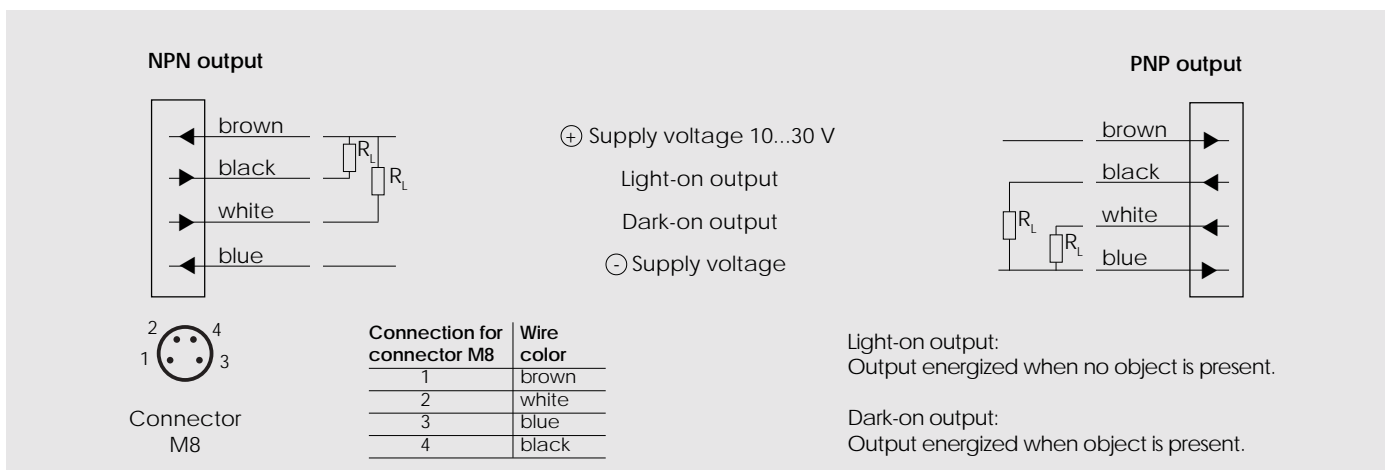

Retro-reflective sensors with polarizing filters, ultramini



- Front or back mounting in the direction of the optical axis
- Glass protected optics
- Light reserve warning indicator
- Insensitive to foreign light sources, e.g. HF-lamps, etc.
- «Cross-talk» suppression for elimination of mutual disturbances
- Dual transistor outputs, NPN or PNP
- Short-circuit protection, reverse polarity protection, and power-up output suppression
- Connections: Cable, 2 meter
Connector, M8
- EMC tested according to IEC 801 and EN50081-1/EN 50082-2



Product designation¹⁾

| |
|--|
| Output |
| Connection |
| Range adjustment |
| Optical data ²⁾ |
| Range |
| Emitter |
| Electrical data ²⁾ |
| Supply voltage U_s |
| Allowable ripple |
| Current consumption (without load) |
| Max. load current I_L |
| Residual voltage |
| Max. switching frequency |
| Environmental data |
| Sealing |
| Temperatrer T_A (operating and storage) |
| Weight |

| OUP 1NA 140 R1 | OUP 1NA 540 R1 | OUP 1PA 140 R1 | OUP 1PA 540 R1 |
|---|-------------------|--------------------------|-------------------|
| NPN (light- and dark-on) | | PNP (light- and dark-on) | |
| Cable 2 m | Connector M8 | Cable 2 m | Connector M8 |
| No | | | |
| 0,03...1 m (retroreflector OZR 001) | | | |
| Visible-red LED, 645 nm, pulsed, with polarizing filter | | | |
| 10...30 VDC | | | |
| +/- 10% of U_s | | | |
| < 15 mA | | | |
| 100 mA | | | |
| < 1,6 V | | | |
| 1000 Hz | | | |
| IP 67 | | | |
| -25...+65 °C | | | |
| ca. 45 g | ca. 4 g | ca. 45 g | ca. 4 g |

1) For product designation of sensors with options see designation code on page 13.

2) When not otherwise noted, all technical data at $T_A = 25\text{ °C}$ and $U_s = 24\text{ V}$.

| Retro-reflector ● | Range | Retro-reflector ■ | Range | Retro-reflective tape | Range |
|-------------------|---------------|-------------------|--------------|-----------------------|---------------|
| OZR 001 | 0.03 – 1.0 m | OZR 101 | 0.03 – 1.6 m | OZR 201 | 0 m |
| OZR 002 | 0.02 – 0.9 m | OZR 102 | 0.03 – 0.5 m | OZR 202 | 0 m |
| OZR 003 | 0.02 – 0.35 m | OZR 103 | 0.03 – 1.2 m | OZR 203 | 0.10 – 0.6 m |
| | | OZR 104 | 0.03 – 2.1 m | OZR 204* | 0.10 – 0.45 m |
| | | | | OZR 205* | 0.10 – 0.55 m |

* 30 cm long

10...30 VDC

NPN / PNP
light-on and
dark-on output

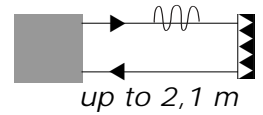

OUP

Dimensions (30 mm x 10 mm x 14 mm)

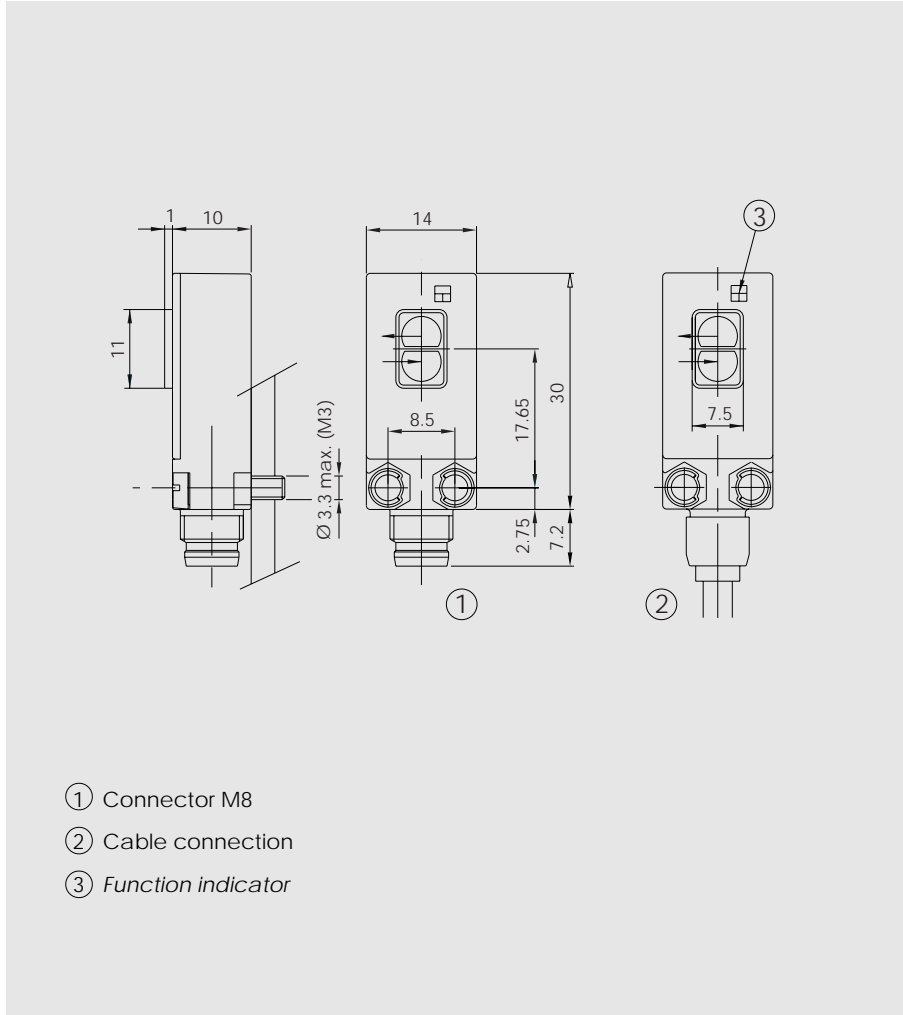

Optical diagrams

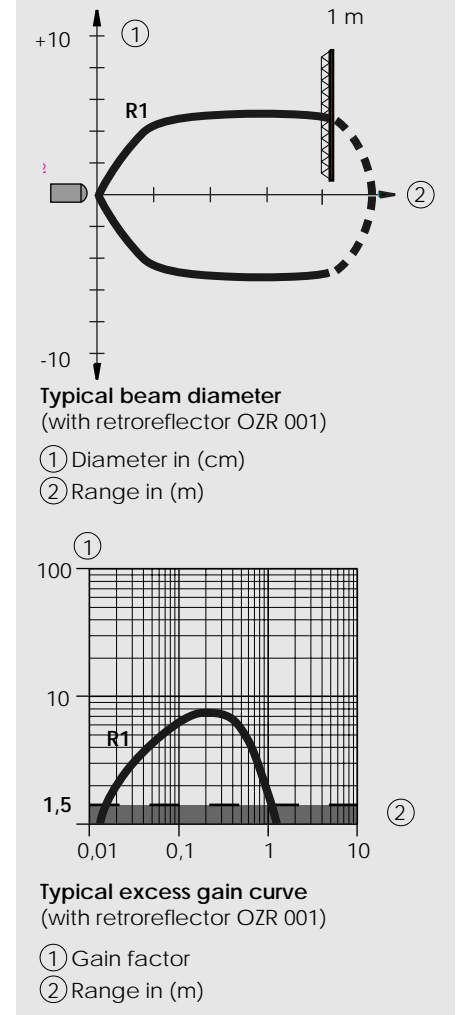

Wiring diagram

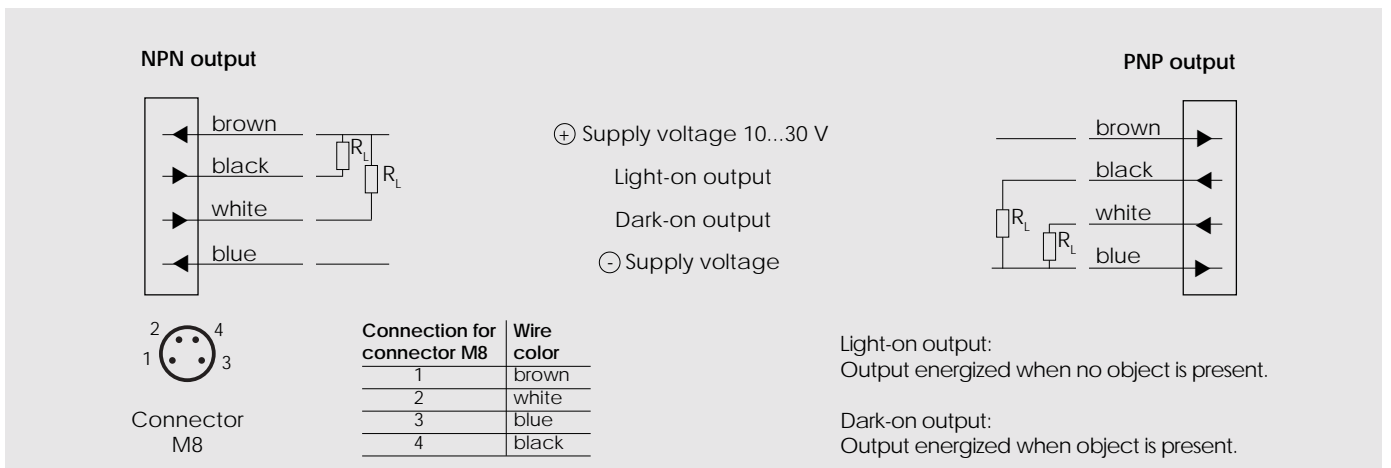

Retro-reflective sensors with polarizing filters, ultramini, for transparent objects



- Front or back mounting in the direction of the optical axis
- Glass protected optics
- Light reserve warning indicator
- Insensitive to foreign light sources, e.g. HF-lamps, etc.
- «Cross-talk» suppression for elimination of mutual disturbances
- Dual transistor outputs, NPN or PNP
- Short-circuit protection, reverse polarity protection, and power-up output suppression
- Connections: Cable, 2 meter
Connector, M8
- EMC tested according to IEC 801 and EN50081-1/EN 50082-2



Product designation¹⁾

| |
|--|
| Output |
| Connection |
| Range adjustment |
| Optical data ²⁾ |
| Range |
| Emitter |
| Electrical data ²⁾ |
| Supply voltage U_s |
| Allowable ripple |
| Current consumption (without load) |
| Max. load current I_L |
| Residual voltage |
| Max. switching frequency |
| Environmental data |
| Sealing |
| Temperatrer T_A (operating and storage) |
| Weight |

| OUC 1NA 100 R2 | OUC 1NA 500 R2 | OUC 1PA 100 R2 | OUC 1PA 500 R2 |
|---|-------------------|--------------------------|-------------------|
| NPN (light- and dark-on) | | PNP (light- and dark-on) | |
| Cable 2 m | Connector M8 | Cable 2 m | Connector M8 |
| Yes | | | |
| 0,05...1,2 m (retroreflector OZR 104) | | | |
| Visible-red LED, 645 nm, pulsed, with polarizing filter | | | |
| | | 10...30 VDC | |
| | | +/- 10% of U_s | |
| | | < 15 mA | |
| | | 100 mA | |
| | | < 1,6 V | |
| | | 1000 Hz | |
| IP 67 | | | |
| -25...+65 °C | | | |
| ca. 45 g | ca. 4 g | ca. 45 g | ca. 4 g |

1) For product designation of sensors with options see designation code on page 13.

2) When not otherwise noted, all technical data at $T_A = 25\text{ °C}$ and $U_s = 24\text{ V}$.

Technical explanation

To detect very transparent objects, best results are obtained, when decreasing the range adjustment of the sensor to the threshold, between a continuously lit function indicator and a blinking function indicator. In this condition (function indicator blinking) a glass window inserted into the optical path, will be reliably detected.

| Retro-reflector ● | Range | Retro-reflector ■ | Range | Retro-reflective tape | Range |
|-------------------|--------------|-------------------|--------------|-----------------------|-------|
| OZR 001* | 0.05 – 0.8 m | OZR 101 | 0.05 – 0.9 m | OZR 201 | 0 m |
| OZR 002 | 0.04 – 0.4 m | OZR 102 | 0.05 – 0.4 m | OZR 202 | 0 m |
| OZR 003 | 0.05 – 0.1 m | OZR 103 | 0.05 – 0.8 m | OZR 203 | 0 m |
| | | OZR 104 | 0.05 – 1.2 m | OZR 204 | 0 m |
| | | | | OZR 205 | 0 m |

* not recommended for bottle detection

10...30 VDC

NPN / PNP
light-on and
dark-on output

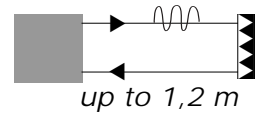

OUC

Dimensions (30 mm x 10 mm x 14 mm)

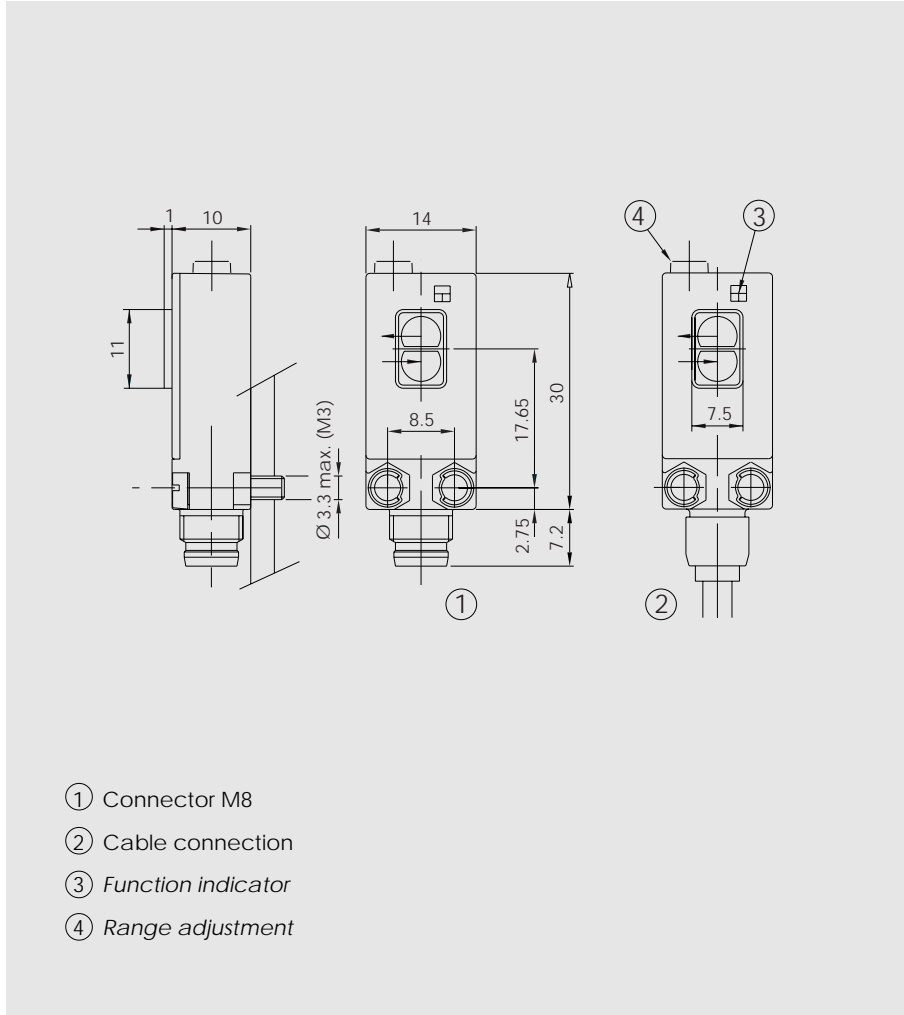

Optical diagrams

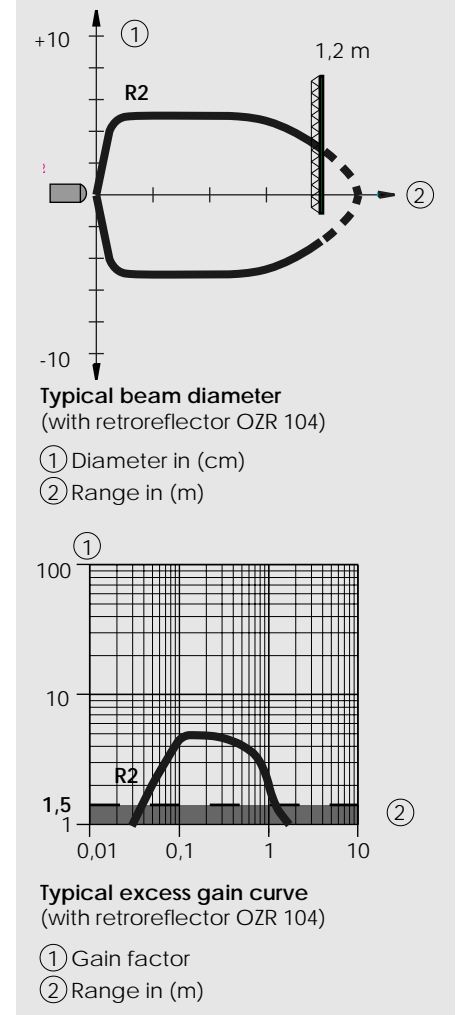

Wiring diagram

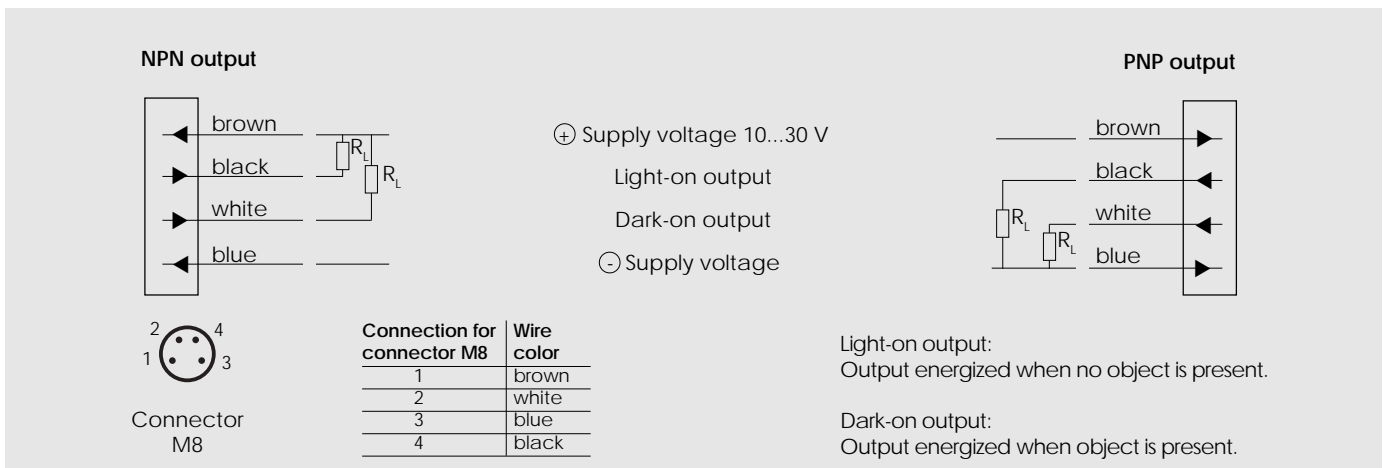

Diffuse-reflective sensors, range 5/10 cm, ultramini



- Front or back mounting in the direction of the optical axis
- Range adjustable
- Light reserve warning indicator
- Insensitive to foreign light sources, e.g. HF-lamps, etc.
- «Cross-talk» suppression for elimination of mutual disturbances
- Dual transistor outputs, NPN or PNP
- Short-circuit protection, reverse polarity protection, and power-up output suppression
- Connections: Cable, 2 meter
Connector, M8
- EMC tested according to IEC 801 and EN50081-1/EN 50082-2



Product designation ¹⁾

Output

Connection

Range adjustment

Optical data ²⁾

Max. range

Emitter

Electrical data ²⁾

Supply voltage U_s

Allowable ripple

Current consumption (without load)

Max. load current I_L

Residual voltage

Max. switching frequency

Environmental data

Sealing

Temperature T_A
(operating and storage)

Weight

| OUT 1NA 100 R1 | OUT 1NA 500 R1 | OUT 1PA 100 R1 | OUT 1PA 500 R1 | OUT 1NA 100 R2 | OUT 1NA 500 R2 | OUT 1PA 100 R2 | OUT 1PA 500 R2 |
|-------------------------------------|-------------------|----------------------|-------------------|--------------------------------------|-------------------|----------------------|-------------------|
| NPN (light-/dark-on) | | PNP (light-/dark-on) | | NPN (light-/dark-on) | | PNP (light-/dark-on) | |
| Cable 2 m | Connector M8 | Cable 2 m | Connector M8 | Cable 2 m | Connector M8 | Cable 2 m | Connector M8 |
| Yes | | | | | | | |
| 5 cm (Kodak card white, 10 x 10 cm) | | | | 10 cm (Kodak card white, 10 x 10 cm) | | | |
| Red-LED, 650 nm, pulsed | | | | | | | |
| 10...30 VDC | | | | | | | |
| +/- 10% of U_s | | | | | | | |
| < 15 mA | | | | | | | |
| 100 mA | | | | | | | |
| < 1,6 V | | | | | | | |
| 1000 Hz | | | | | | | |
| IP 67 | | | | | | | |
| -25...+65 °C | | | | | | | |
| ca. 45 g | ca. 4 g | ca. 45 g | ca. 4 g | ca. 45 g | ca. 4 g | ca. 45 g | ca. 4 g |

1) For product designation of sensors with options see designation code on page 13.

2) When not otherwise noted, all technical data at $T_A = 25\text{ °C}$ and $U_s = 24\text{ V}$.

10...30 VDC

NPN / PNP
light-on and
dark-on output

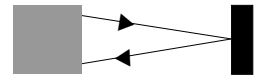

5/10 cm

OUT

Dimensions (30 mm x 10 mm x 14 mm)

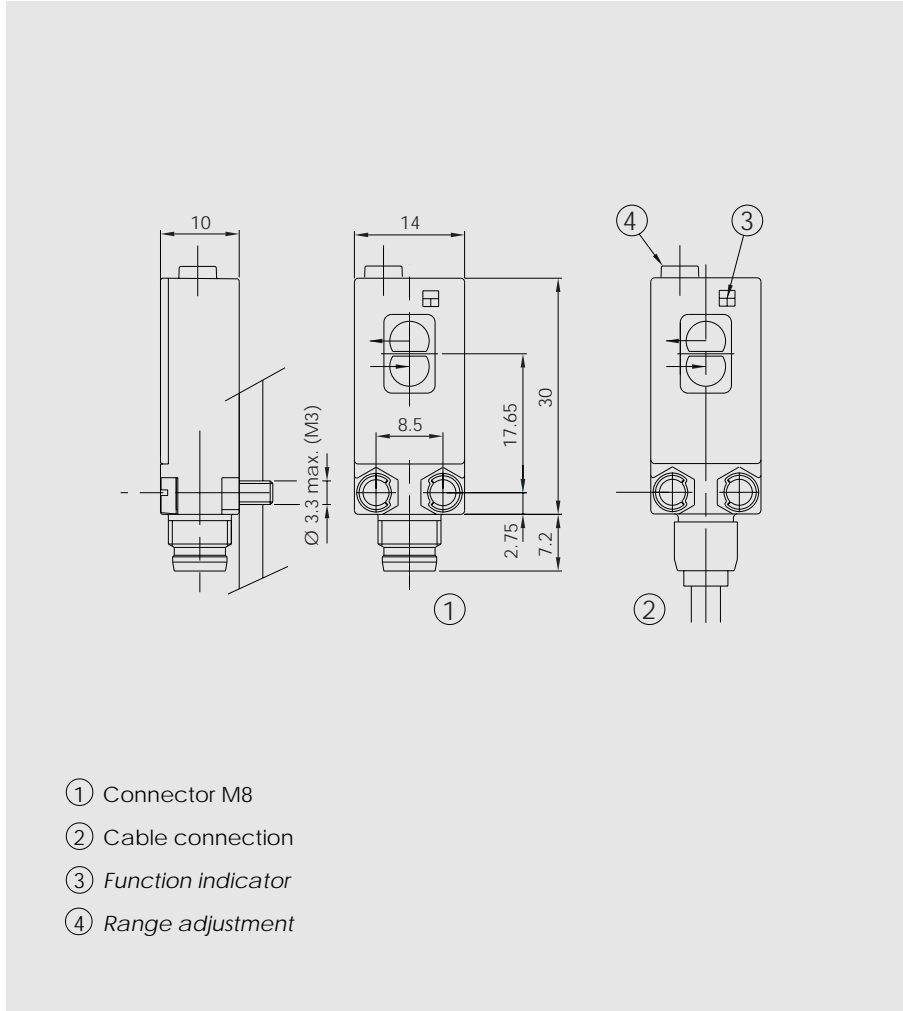

Optical diagrams

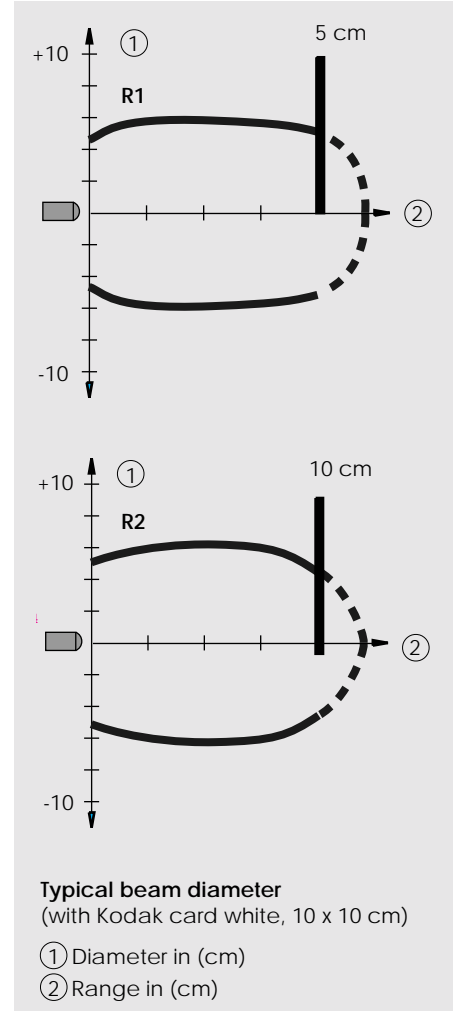

Wiring diagram

