

Series M1L

Strong and precise – the fast M18 laser sensors

 up to 100 m
Through-beam sensors M1LS/M1LE

 up to 12 m
Retro-reflective sensors
with polarizing filters M1LP

 up to 30 cm
Diffuse-reflective sensors M1LT



Laser class 1



High functionality

Diverse operating principles

The M1L laser sensors are available as through-beam sensors, retro-reflective sensors with polarizing filters and diffuse-reflective sensors.

Enormous ranges, high geometrical resolution

Thanks to newest technology and high quality optics in emitter and receiver enormous ranges and high geometrical resolution are achieved. The laser beam geometry of all M1L laser sensors is fixed and suitable for most of the applications. On request, sensors with customized beam characteristics are available.

High switching frequency

All M1L laser sensors have an enormous switching frequency of 5000 Hz. It allows the reliable detection of even very fast events. The short response time of 0.1 ms enables high-precision switching, e.g. in fast positioning tasks.

Light reserve warning indicator

All M1L laser sensors are equipped with a *light-reserve warning indicator* (blinking function indicator) to control dirt build-up on the lenses or to be used as an alignment aid.

Low power consumption

Despite their high optical performance the power consumption of the M1L sensors is very low.

Test input

As standard, all the M1LS laser through-beam emitters have a *test input*.

Simple installation and operation

Well visible laser spot

The red laser spot of the M1L sensors is well visible over long distances. This makes alignment easy.

Optimised laser beam

For each M1L sensor type, the beam geometry is optimised. The laser beam is convergent with fixed focus. Near the focus, highest resolution or most precise positioning can be achieved. In the far field the beam is widened up, which enables reliable operation at high ranges.

Various connection versions

All M1L laser sensors are available standard with a 4 wire 2 m cable or a 4 pin M12 connector.

User friendly adjustment button with integrated function indicator

The optical range of each M1L laser sensor can be adjusted to meet the specific application. The adjustment is made comfortably on a large and robust button. The function indicator is integrated in the adjustment button and is visible over a wide angle.



Reliable for the highest demands

Robust construction with IP 67 sealing

The M1L laser photoelectric sensors are built with a polyamide 12 or stainless steel housing, and are protected against water and dust. The sensors meet the *sealing* requirements of IP 67.

EMC-tested

The M1L laser sensors are tested according to EN 61000-6-1/2/3/4. This assures trouble free use even in high electromagnetically contaminated environments.

High ambient light rejection

Thanks to pulse modulation and a multilevel disturbance rejection, the M1L laser sensors are extremely insensitive to foreign light sources.

Reverse polarity protection

All of the M1L laser sensor electrical connections are protected against reverse wiring.

Short-circuit protection

The M1L laser sensor transistor outputs are electronically protected against short circuit.

Power-up output suppression

During power-up the outputs of the M1L laser sensors are blocked for typically 30 msec.

Laser class

All M1L laser sensors meet laser class 1 (IEC 825-1; EN 60825-1:2001)

Designation code

M1L X XXX XXX XXX

Housing
: Polyamide
M: Stainless steel

Principle	Supply	Outputs	Connection	Electr. option	Light	Range
<p>E: Through-beam receiver</p> <p>P: Retro-reflective with polarizing filters</p> <p>S: Through-beam emitter</p> <p>T: Diffuse-reflective</p>	1: 10-30 VDC	<p>KA: No output</p> <p>NA: NPN <i>light- and dark-on</i></p> <p>PA: PNP <i>light- and dark-on</i></p>	<p>1: Cable 2 m</p> <p>4: Connector M12</p>	<p>00: Range adjustable</p> <p>01: Range adjustable, <i>test input</i></p> <p>40: Range not adjustable</p>	R: Straight optic, red	<p>M1LS/M1LE: 1: 100 m</p> <p>M1LP: 1: 12 m</p> <p>M1LT: 1: 30 cm</p>

Accessories

Retroreflectors: see page 130

Connector cables: see page 128

Mounting:

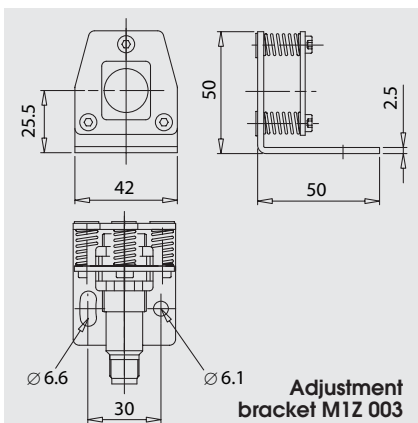
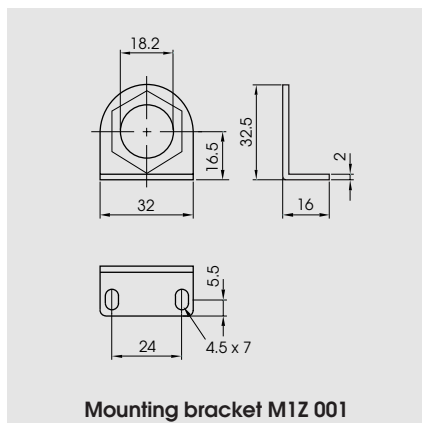

Through-beam sensors, laser, M18 housing



- High optical range, adjustable
- 5000 Hz switching frequency for fast and precise switching
- Fix laser beam geometry, convergent
- Laser class 1
- Test input for system analysis
- Short-circuit protection, reverse polarity protection and power-up output suppression
- Connections: Cable, 2 meter
Connector, M12
- EMC tested according to EN 61000-6-1/2/3/4



Product designation Plastic housing ¹⁾

Product designation Stainless steel ¹⁾

Output

Connection

Range adjustment

Optical data ²⁾

Max. range

Emitter

Electrical data ²⁾

Supply voltage U_s

Allowable ripple

Current consumption (without load)

Max. load current I_L

Residual voltage

Max. switching frequency

Test input: emitter on
emitter off

Test input inverse: emitter on
emitter off

Environmental data

Sealing

Laser class

Temperature T_A
(operating and storage)

Weight Plastic/Stainless steel

Emitter		Receiver			
M1LS 1KA 101 R1	M1LS 1KA 401 R1	M1LE 1NA 140 R1	M1LE 1NA 440 R1	M1LE 1PA 140 R1	M1LE 1PA 440 R1
M1LS 1KA 101 R1M	M1LS 1KA 401 R1M	M1LE 1NA 140 R1M	M1LE 1NA 440 R1M	M1LE 1PA 140 R1M	M1LE 1PA 440 R1M
		NPN (light-/dark-on)		PNP (light-/dark-on)	
Cable 2 m	Connector M12	Cable 2 m	Connector M12	Cable 2 m	Connector M12
Yes		No			
100 m					
Laser, red 650 nm, pulsed					
10...30 VDC					
+/- 10% of U_s					
< 15 mA		< 15 mA			
		100 mA			
		< 1,6 V			
5000 Hz					
> 8 V or open < 1,5 V					
Open or < 1,5 V > 8 V					
IP 67					
1 (IEC 825-1; EN 60825-1:2001)					
-25...+60 °C					
Connector M12: ca.15/25 g , Cable 2 m: ca. 100/110 g					

1) For product designation of sensors with options see designation code.
2) When not otherwise noted, all technical data at $T_A = 25\text{ °C}$ and $U_s = 24\text{ V}$.

Option

Receiver with integrated optical aperture for the detection of small objects or for precise positioning.

Designation	Round aperture	Range
M1LE xxx xxx R96x	∅ 1.0 mm	15 m

10...30 VDC
 NPN / PNP
 light-on and
 dark-on output

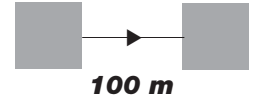

100 m

M1LS/M1LE

Dimensions (50 mm, M18 x 1)

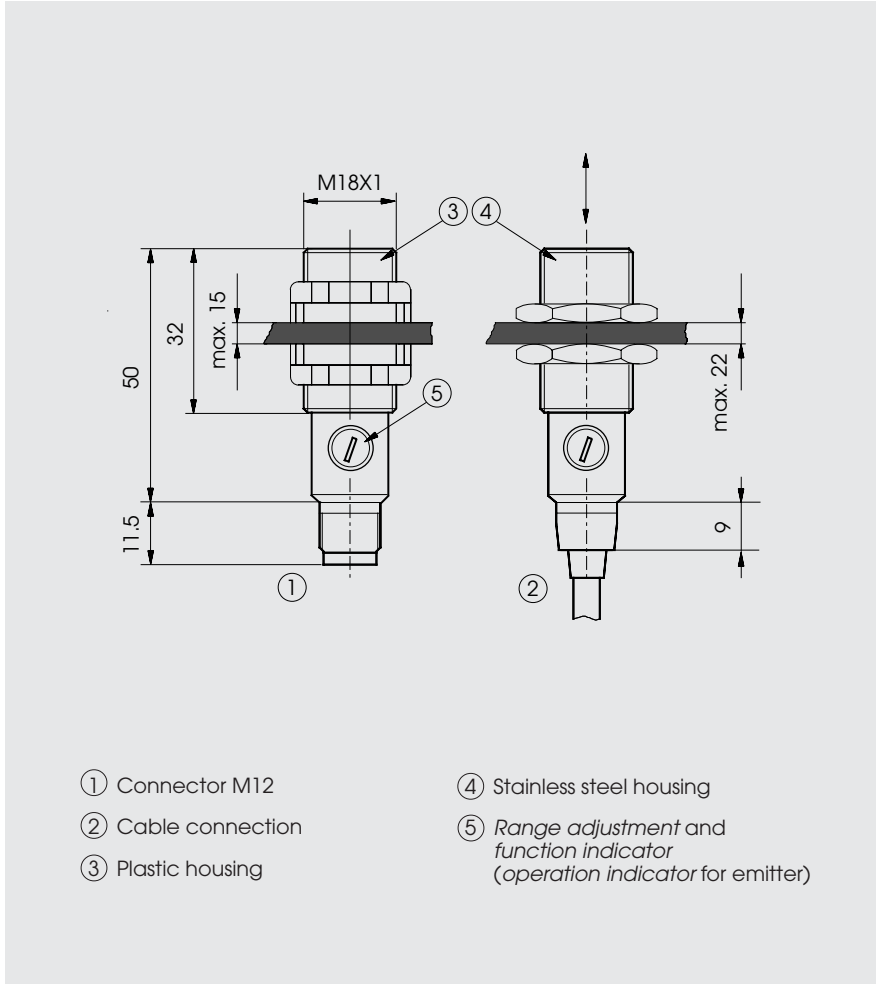

Optical diagrams

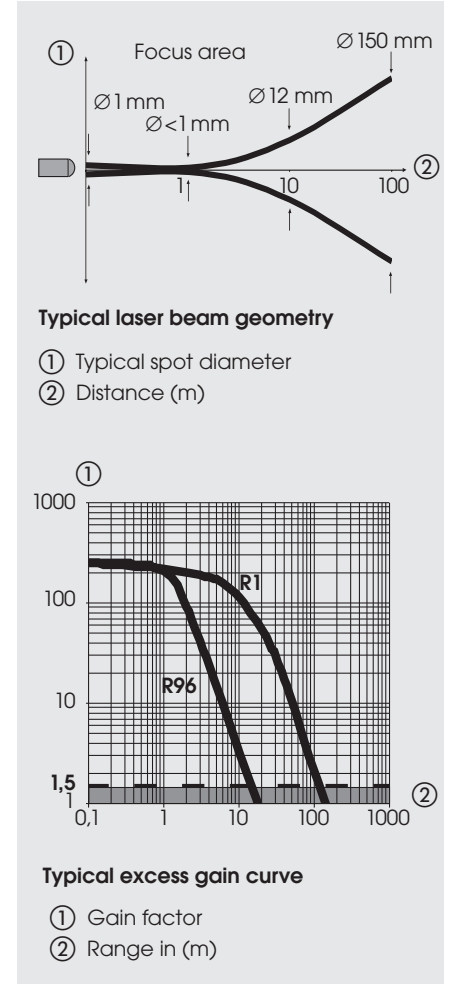

Wiring diagram

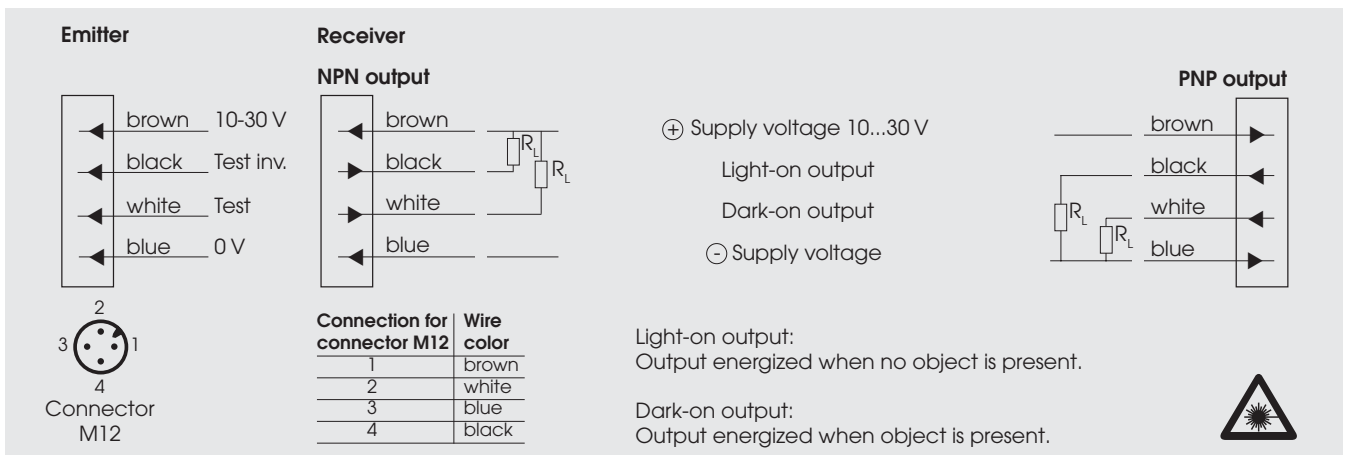

Retro-reflective sensors, laser, with polarizing filters, M18 housing



- Large optical range, adjustable
- 5000 Hz switching frequency for fast and precise switching
- Fix laser beam geometry, convergent
- Laser class 1
- Dual transistor outputs
- Short-circuit protection, reverse polarity protection and power-up output suppression
- Connections: Cable, 2 meter
Connector, M12
- EMC tested according to EN 61000-6-1/2/3/4



Product designation Plastic housing ¹⁾

Product designation Stainless steel ¹⁾

Output

Connection

Range adjustment

Optical data ²⁾

Max. Range

Emitter

Electrical data ²⁾

Supply voltage U_s

Allowable ripple

Current consumption (without load)

Max. load current I_L

Residual voltage

Max. switching frequency

Environmental data

Sealing

Laser class

Temperature T_A
(operating and storage)

Weight Plastic/Stainless steel

M1LP 1NA 100 R1	M1LP 1NA 400 R1	M1LP 1PA 100 R1	M1LP 1PA 400 R1
M1LP 1NA 100 R1M	M1LP 1NA 400 R1M	M1LP 1PA 100 R1M	M1LP 1PA 400 R1M
NPN (light-/dark-on)		PNP (light-/dark-on)	
Cable 2 m	Connector M12	Cable 2 m	Connector M12
Ja			
0,12 ... 12 m (Reflector OZR 105)			
Laser, red, 650 nm, pulsed			
10...30 VDC			
+/- 10% von U_s			
< 20 mA			
100 mA			
< 1,6 V			
5000 Hz			
IP 67			
1 (IEC 825-1; EN 60825-1:2001)			
-25...+60 °C			
Connector M12: ca.15/25 g , Cable 2 m: ca. 100/110 g			

1) For product designation of sensors with options see designation code.
2) When not otherwise noted, all technical data at $T_A = 25\text{ °C}$, $U_s = 24\text{ V}$.

Remark:

To achieve optimal results for the laser retro-reflective sensors M1LP, retro-reflectors with fine structure (e.g. OZR 004, OZR 105) are recommended.

Retro-reflector ●	Range	Retro-reflector ■	Range	Retro-reflective tape	Range
OZR 001	0.15 – 6 m	OZR 101	0.15 – 8 m	OZR 201	0 m
OZR 002	0.15 – 8 m	OZR 102	0.15 – 3.5 m	OZR 202	0 m
OZR 003	0.15 – 4 m	OZR 103	0.12 – 12 m	OZR 203	0.15 – 1.3 m
OZR 004	0.15 – 6 m	OZR 104	0.12 – 12 m	OZR 204*	0.15 – 1.1 m
		OZR 105	0.12 – 12 m	OZR 205*	0.15 – 1.1 m

* 50 mm long

10...30 VDC
 NPN / PNP
 light-on and
 dark-on output

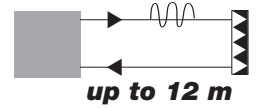

M1LP

Dimensions (50 mm, M18 x 1)

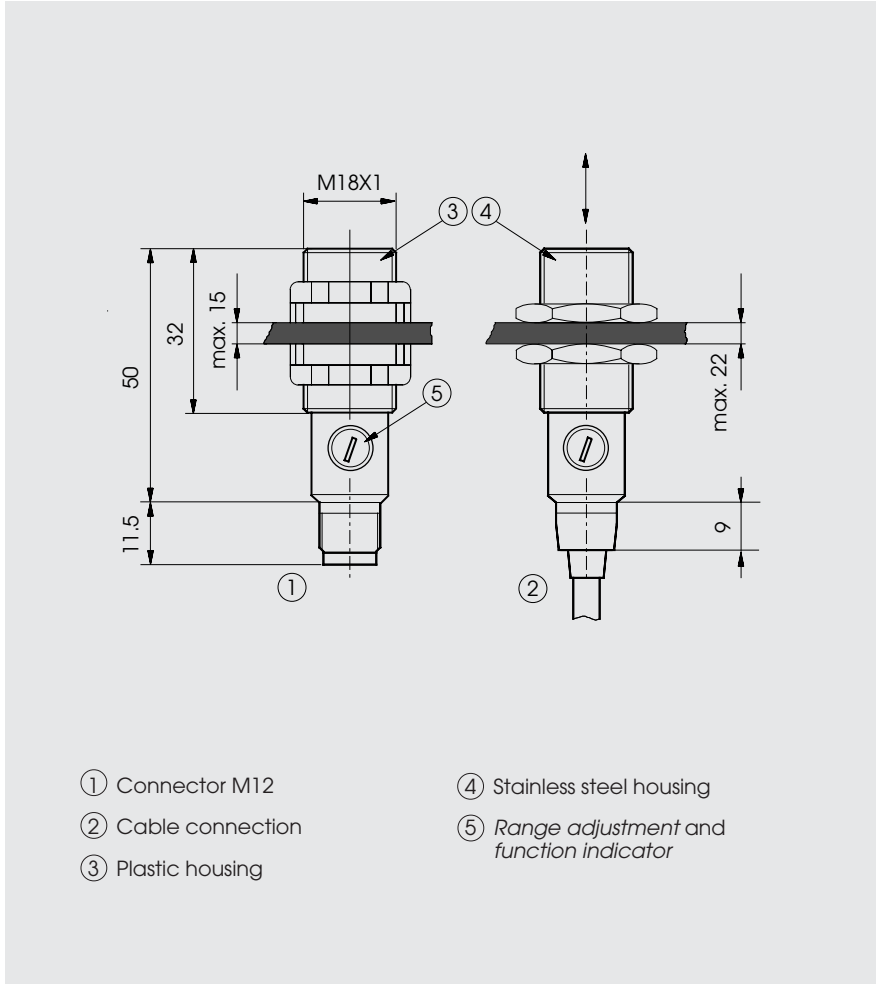

- ① Connector M12
- ② Cable connection
- ③ Plastic housing
- ④ Stainless steel housing
- ⑤ Range adjustment and function indicator

Optical diagrams

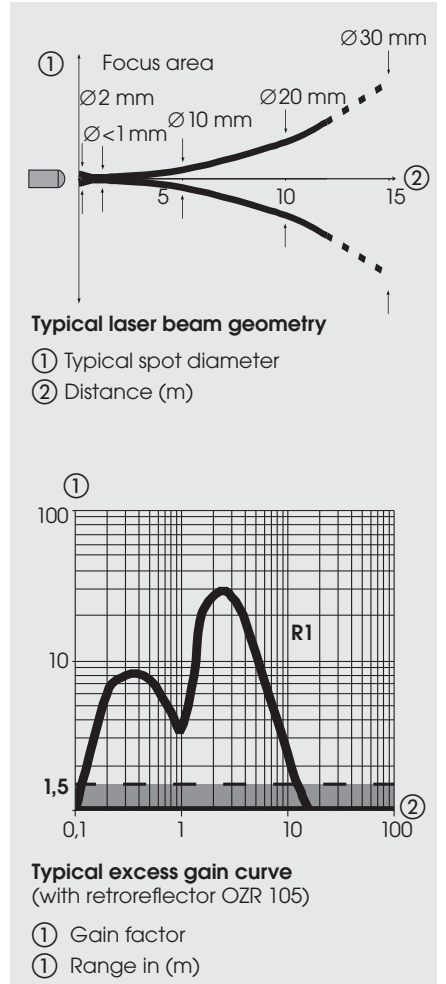

Typical laser beam geometry

- ① Typical spot diameter
- ② Distance (m)

Typical excess gain curve
 (with retroreflector OZR 105)

- ① Gain factor
- ① Range in (m)

Wiring diagram

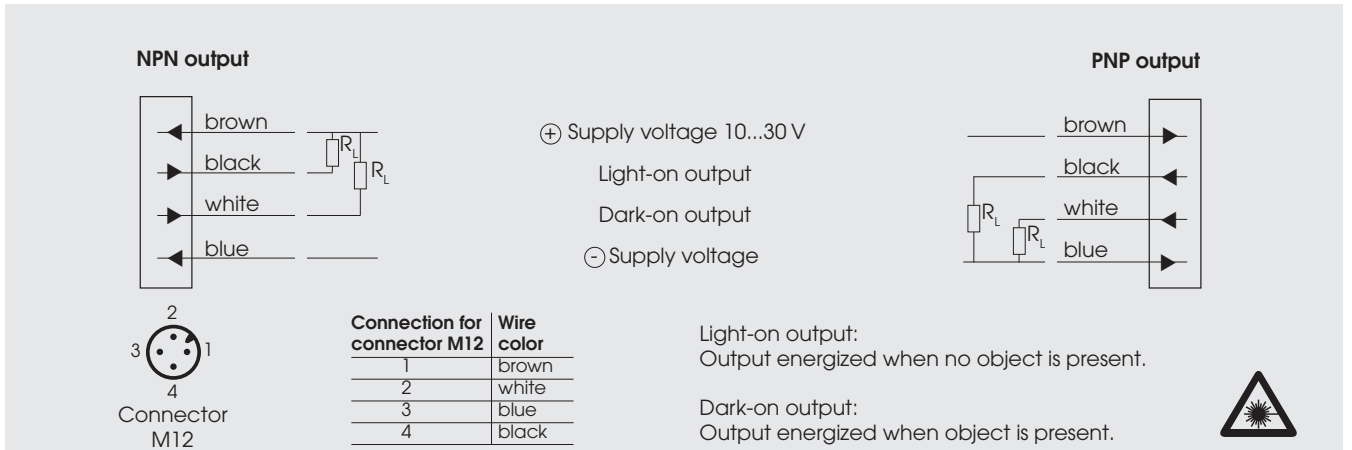

Diffuse-reflective sensors, laser, range 30 cm, M18 housing



- Range adjustable
- 5000 Hz switching frequency for fast and precise switching
- Convergent laser beam, focus at approx. 10 cm
- Laser class 1
- Short-circuit protection, reverse polarity protection and power-up output suppression
- Connections: Cable, 2 meter
Connector, M12
- EMC tested according to EN 61000-6-1/2/3/4



Product designation Plastic housing ¹⁾

Product designation Stainless steel ¹⁾

Output

Connection

Range adjustment

Optical data ²⁾

Max. Range

Emitter

Electrical data ²⁾

Supply voltage U_s

Allowable ripple

Current consumption (without load)

Max. load current I_L

Residual voltage

Max. switching frequency

Environmental data

Sealing

Laser class

Temperature T_A
(operating and storage)

Weight Plastic/Stainless steel

M1LT 1NA 100 R1	M1LT 1NA 400 R1	M1LT 1PA 100 R1	M1LT 1PA 400 R1
M1LT 1NA 100 R1M	M1LT 1NA 400 R1M	M1LT 1PA 100 R1M	M1LT 1PA 400 R1M
NPN (light-/dark-on)		PNP (light-/dark-on)	
Cable 2 m	Connector M12	Cable 2 m	Connector M12
Yes			
30 cm (Kodak card white, 10 x 10 cm)			
Laser, red, 650 nm, pulsed			
10...30 VDC			
+/- 10% von U_s			
< 20 mA			
100 mA			
< 1,6 V			
5000 Hz			
IP 67			
1 (IEC 825-1; EN 60825-1:2001)			
-25...+60 °C			
Connector M12: ca.15/25 g , Cable 2 m: ca. 100/110 g			

1) For product designation of sensors with options see designation code.
2) When not otherwise noted, all technical data at $T_A = 25\text{ °C}$, $U_s = 24\text{ V}$.

10...30 VDC
 NPN / PNP
 light-on and
 dark-on output

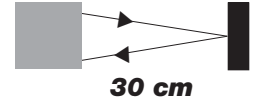

M1LT

Dimensions (50 mm, M18 x 1)

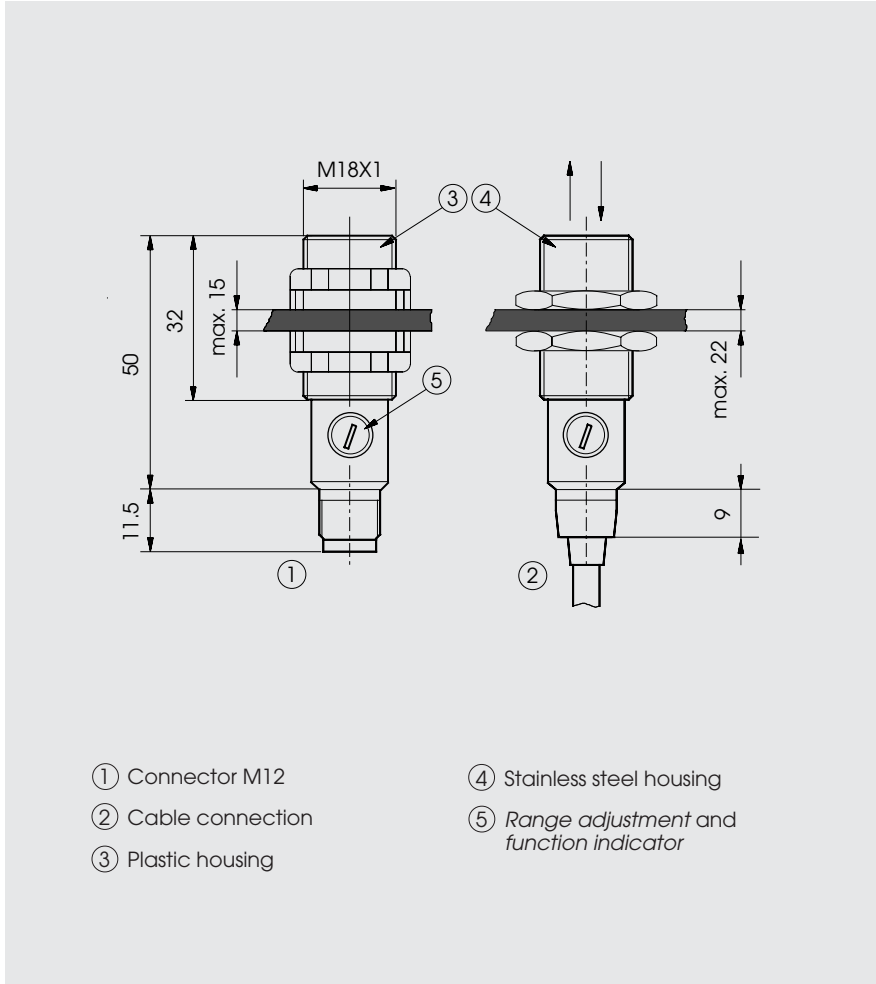

Optical diagrams

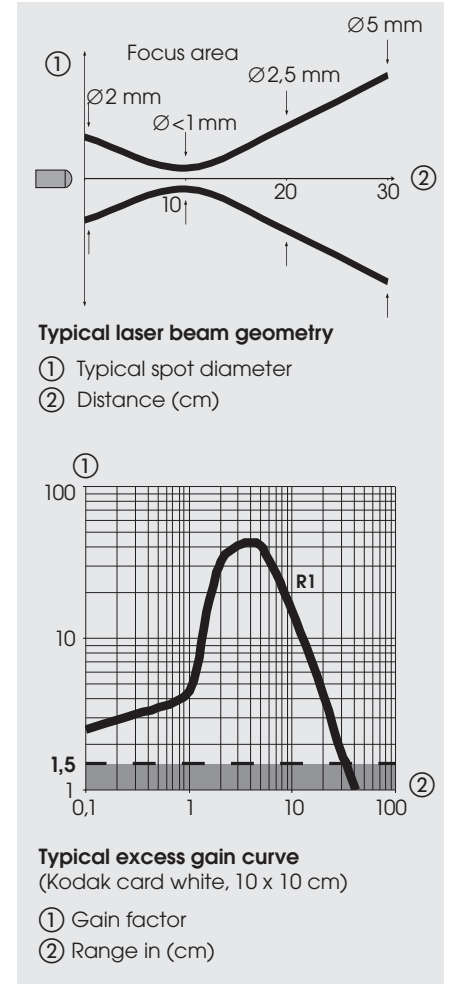

Wiring diagram

