

# Through-beam sensors, straight optics, M18 housing



- Combined surface and bore mounting
- Light reserve warning indicator
- Dual transistor outputs, NPN or PNP
- Test input
- Short-circuit protection, reverse polarity protection, and power-up output suppression
- Connections: Straight cable, 2 meter  
Connector, M12  
Right angle cable, 2 meter (option)  
Connector, Torson (option)
- EMC tested according to IEC 801 and EN50081-1/EN 50082-2



## Product designation<sup>1)</sup>

Output

Connection

Range adjustment

## Optical data<sup>2)</sup>

Max. range

Emitter

## Electrical data<sup>2)</sup>

Supply voltage  $U_s$

Allowable ripple

Current consumption (without load)

Max. load current  $I_L$

Residual voltage

Max. switching frequency

Test input: emitter on  
emitter off

Test input inverse: emitter on  
emitter off

## Environmental data

Sealing

Temperature  $T_A$   
(operating and storage)

Weight

## Technical explanation

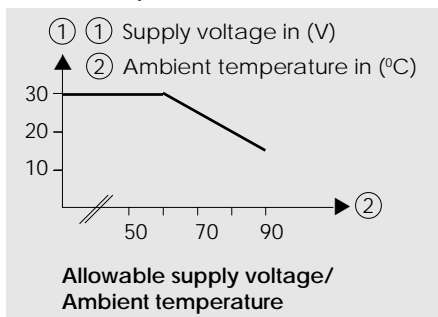

Emitter		Receiver			
OMS 1KA 141 G1	OMS 1KA 441 G1	OME 1NA 100 G1	OME 1NA 400 G1	OME 1PA 100 G1	OME 1PA 400 G1
		NPN (light- and dark-on)		PNP (light- and dark-on)	
Cable 2 m	Connector M12	Cable 2 m	Connector M12	Cable 2 m	Connector M12
No		Yes			
9 m					
Infrared-LED, 880 nm, pulsed					
10...30 VDC					
+/- 10% of $U_s$					
< 25 mA		< 15 mA			
		200 mA			
		< 1,6 V			
		1000 Hz			
> 8 V or open < 1,5 V					
open or < 1,5 V > 8 V					
IP 67					
-20...+90 °C (↔ Tech. explanation)					
ca. 90 g	ca. 20 g	ca. 90 g	ca. 20 g	ca. 90 g	ca. 20 g

1) For product designation of sensors with options see designation code on page 47.

2) When not otherwise noted, all technical data at  $T_A = 25\text{ °C}$  and  $U_s = 24\text{ V}$ .

## Allowable supply voltage as a function of ambient temperature

The specified operating temperature is only usable if the supply voltage is reduced at higher temperatures (↔ Diagram "Allowable supply voltage/Ambient temperature").



# Through-beam sensors, right angle optics, M18 housing



- Combined surface and bore mounting
- Light reserve warning indicator
- Dual transistor outputs, NPN or PNP
- Test input
- Short-circuit protection, reverse polarity protection, and power-up output suppression
- Connections: Straight cable, 2 meter  
Connector, M12  
Right angle cable, 2 meter (option)  
Connector, Torson (option)
- EMC tested according to IEC 801 and EN50081-1/EN 50082-2



## Product designation<sup>1)</sup>

Output

Connection

Range adjustment

## Optical data<sup>2)</sup>

Max. range

Emitter

## Electrical data<sup>2)</sup>

Supply voltage  $U_s$

Allowable ripple

Current consumption (without load)

Max. load current  $I_L$

Residual voltage

Max. switching frequency

Test input: emitter on  
emitter off

Test input inverse: emitter on  
emitter off

## Environmental data

Sealing

Temperature  $T_A$   
(operating and storage)

Weight

## Technical explanation

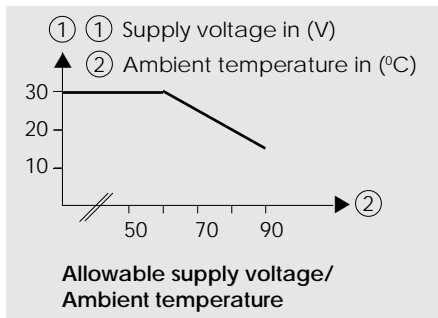

Emitter		Receiver			
OMS 1KA 141 W2	OMS 1KA 441 W2	OME 1NA 100 W2	OME 1NA 400 W2	OME 1PA 100 W2	OME 1PA 400 W2
		NPN (light- and dark-on)		PNP (light- and dark-on)	
Cable 2 m	Connector M12	Cable 2 m	Connector M12	Cable 2 m	Connector M12
No		Yes			
8 m					
Infrared-LED, 890 nm, pulsed					
10...30 VDC					
+/- 10% of $U_s$					
< 25 mA		< 15 mA			
		200 mA			
		< 1,6 V			
		1000 Hz			
> 8 V or open < 1,5 V					
open or < 1,5 V > 8 V					
IP 67					
-20...+90 °C (↔ Tech. explanation)					
ca. 95 g	ca. 25 g	ca. 95 g	ca. 25 g	ca. 95 g	ca. 25 g

1) For product designation of sensors with options see designation code on page 47.  
2) When not otherwise noted, all technical data at  $T_A = 25\text{ °C}$  and  $U_s = 24\text{ V}$ .

## Allowable supply voltage as a function of ambient temperature

The specified operating temperature is only usable if the supply voltage is reduced at higher temperatures (↔ Diagram "Allowable supply voltage/Ambient temperature").

10...30 VDC

NPN / PNP  
light-on and  
dark-on output

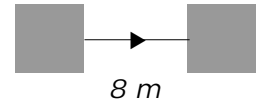

## OMS/OME right angle optics

### Dimensions (71,5 mm, M18 x 1)

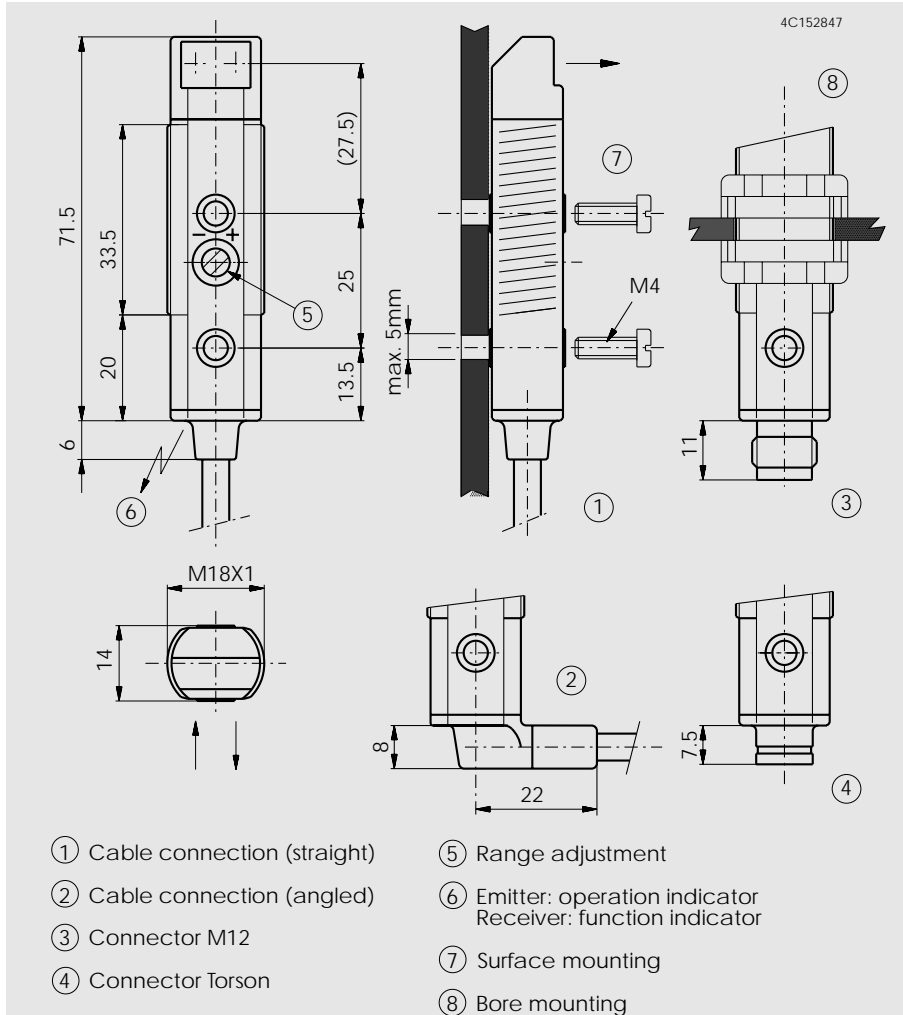

### Optical diagrams

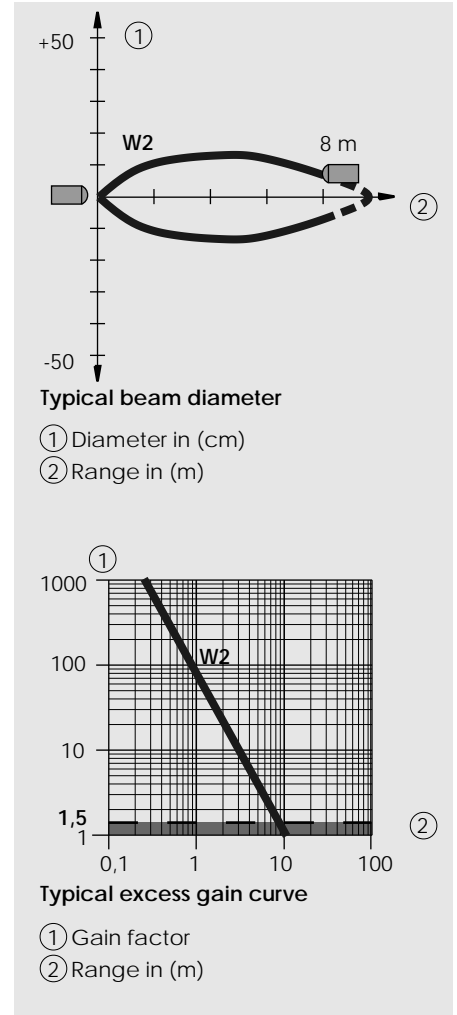

### Wiring diagram

