

# Through-beam sensors, in a robust plastic housing



- DC or AC/DC supply voltage
- Short-circuit protected dual transistor outputs (NPN oder PNP) or relay output with 1 change over contact
- Reverse polarity protection and power-up output suppression
- Light reserve warning indicator
- Test input on DC sensors
- Versions with red light and beam angle  $< \pm 2^\circ$  available
- Cable 2 m or connector M12, rotatable
- EMC tested according to IEC 801 and EN 50081-2/EN 50082-2



## Product designation <sup>1)</sup>

Output
Connection
Range adjustment

## Optical data <sup>2)</sup>

Max. range
Emitter

## Electrical data <sup>2)</sup>

Supply voltage $U_s$
Allowable ripple
Current consumption (without load)
Max. load current $I_L$
Residual voltage
Max. switching frequency
Test input: emitter on emitter off

## Environmental data

Sealing
Temperature $T_A$ (operating and storage)
Weight

Emitter		Receiver				Emitter	Receiver
OGS 1KA 141 I1	OGS 1KA 441 I1	OGE 1NA 100 I1	OGE 1NA 400 I1	OGE 1PA 100 I1	OGE 1PA 400 I1	OGS 7KA 140 I1	OGE 7HW 100 I1
		NPN (light-/dark-on)		PNP (light-/dark-on)			Relay
Cable 2 m	Connector M12	Cable 2 m	Connector M12	Cable 2 m	Connector M12	Cable 2 m	
No		Yes				No	Yes
50 m							
Infrared-LED 880 nm, pulsed						Infrared-LED 880 nm, pulsed	
10...30 VDC						24...240 VAC/DC	
+/-10% of $U_s$							
< 25 mA		< 15 mA				< 2 VA	
		200 mA				2A	
		< 1,6 V					
		1000 Hz				25 Hz	
+ $U_s$ or open < 1 V							
IP 67							
-25...+65 °C							
ca. 140 g	ca. 100 g	ca. 140 g	ca. 100 g	ca. 140 g	ca. 100 g	ca. 200 g	

1) For product designation of sensors with options see designation code on page 93.

2) When not otherwise noted, all technical data at  $T_A = 25^\circ\text{C}$  and  $U_s = 24\text{ VDC}$  or  $U_s = 220\text{ VAC}$ , respectively.

24...240 VAC/DC

10...30 VDC

Relay  
1 CO contact

NPN / PNP  
light-on and  
dark-on output

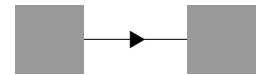

OGS/OGE

Dimensions (68,5 mm x 67 mm x 30 mm)

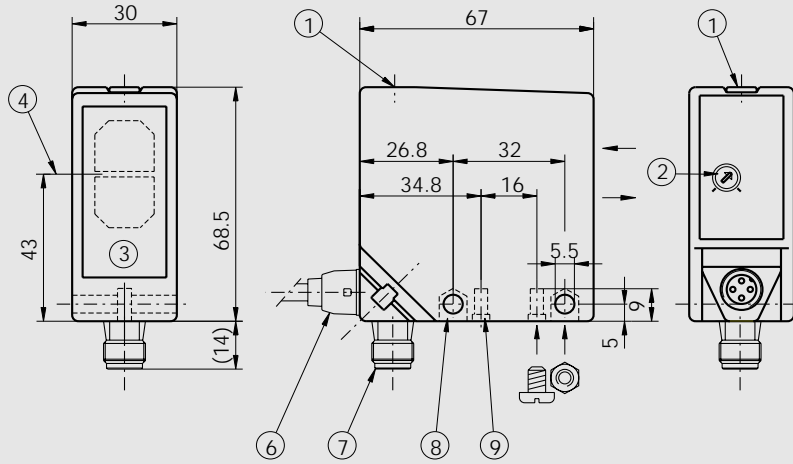

- ① Emitter: operation indicator  
Receiver: function indicator
- ② Range adjustment
- ③ Glass covered optics
- ④ Center of the optical axis
- ⑥ Cable connection
- ⑦ Connector M12
- ⑧ Opening for M5 nut
- ⑨ Bore for 5 mm self-tapping screw

Optical diagrams

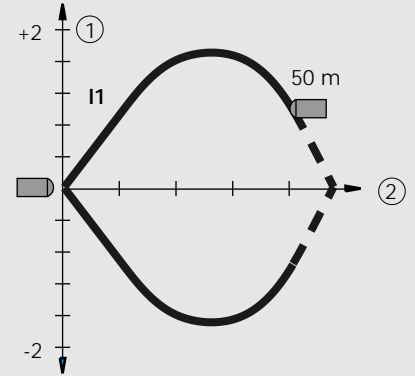

Typical beam diameter

- ① Diameter in (m)
- ② Range in (m)

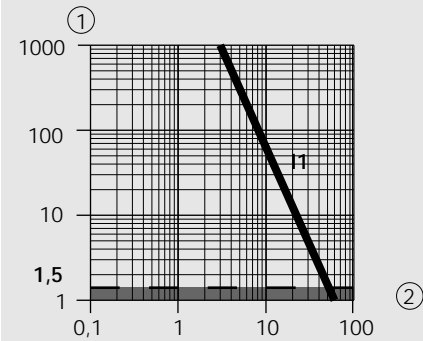

Typical excess gain curve

- ① Gain factor
- ② Range in (m)

Wiring diagram

DC version

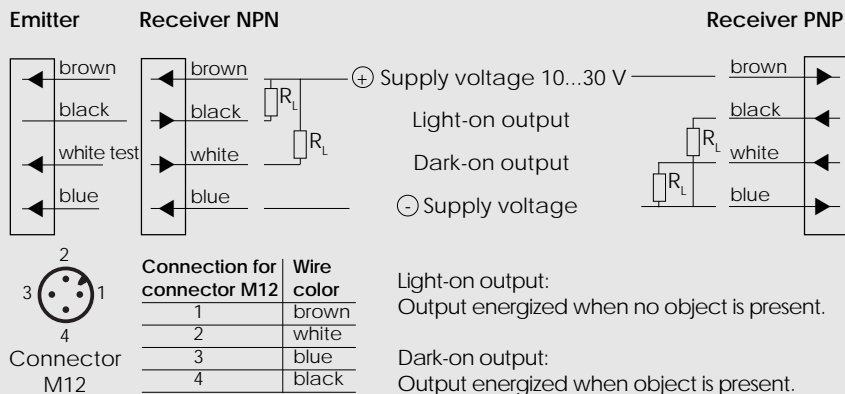

AC/DC version

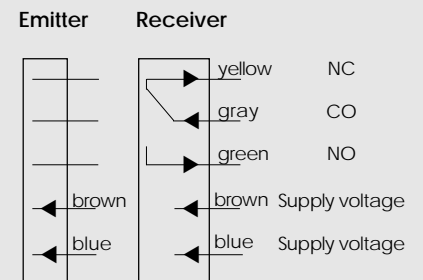

No protective isolation!