

Retro-reflective sensors, in a robust plastic housing



- DC or AC/DC supply voltage
- Short-circuit protected dual transistor outputs (NPN oder PNP) or relay output with 1 change over contact
- Reverse polarity protection and power-up output suppression
- Light reserve warning indicator
- Test input (option on DC sensors)
- Cable 2 m or connector M12, rotatable
- EMC tested according to IEC 801 and EN 50081-2/EN 50082-2



Product designation¹⁾

Output

Connection

Range adjustment

Optical data²⁾

Range

Emitter

Electrical data²⁾

Supply voltage U_s

Allowable ripple

Current consumption (without load)

Max. load current I_L

Residual voltage

Max. switching frequency

Environmental data

Sealing

Temperature T_A
(operating and storage)

Weight

OGR 1NA 100 I2	OGR 1NA 400 I2	OGR 1PA 100 I2	OGR 1PA 400 I2	OGR 7HW 100 I2
NPN (light- and dark-on)		PNP (light- and dark-on)		Relay (light-on)
Cable 2 m	Connector M12	Cable 2 m	Connector M12	Cable 2 m
Yes				
0,3...18 m (retroreflector OZR 001)				
Infrared-LED, 890 nm, pulsed				
10...30 VDC			24...240 VAC/DC	
+/- 10% of U_s				
< 15 mA			< 2 VA	
200 mA			2 A	
< 1,6 V				
1000 Hz			25 Hz	
IP 67				
-25...+65 °C				
ca. 140 g	ca. 100 g	ca. 140 g	ca. 100 g	ca. 200 g

Option¹⁾

Test input: emitter on

emitter off

+ U_s or open	
< 1 V	< U_s - 8 V

1) For product designation of sensors with options see designation code on page 93.

2) When not otherwise noted, all technical data at $T_A = 25$ °C and $U_s = 24$ VDC or $U_s = 220$ VAC, respectively.

Retro-reflector ●	Range	Retro-reflector ■	Range	Retro-reflective tape	Range
OZR 001	0.3 – 18 m	OZR 101	0.03 – 25 m	OZR 201*	0.4 – 6 m
OZR 002	0.4 – 16 m	OZR 102	0.3 – 9 m	OZR 202	0.6 – 13 m
OZR 003	0.4 – 8 m	OZR 103	0.4 – 20 m	OZR 203	0.5 – 11 m
		OZR 104	0.4 – 32 m	OZR 204*	0.5 – 11 m
				OZR 205*	0.5 – 15 m

* 30 cm long

24...240 VAC/DC

10...30 VDC

Relay
1 CO contact

NPN / PNP
light-on and
dark-on output

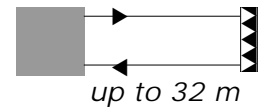

OGR

Dimensions (68,5 mm x 67 mm x 30 mm)

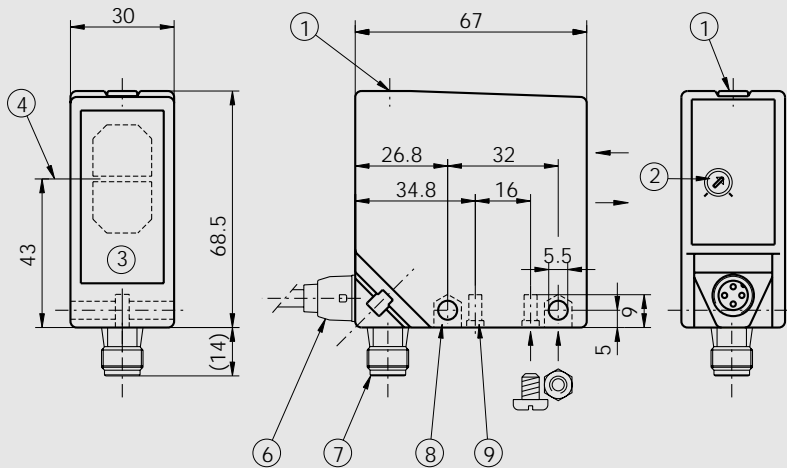

- ① Function indicator
- ② Range adjustment
- ③ Glass covered optics
- ④ Center of the optical axis
- ⑥ Cable connection
- ⑦ Connector M12
- ⑧ Opening for M5 nut
- ⑨ Bore for 5 mm self-tapping screw

Optical diagrams

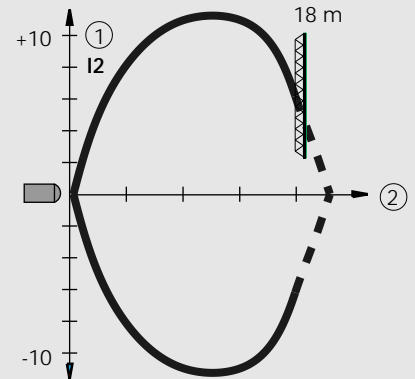

Typical beam diameter
(with retroreflector OZR 001)

- ① Diameter in (cm)
- ② Range in (m)

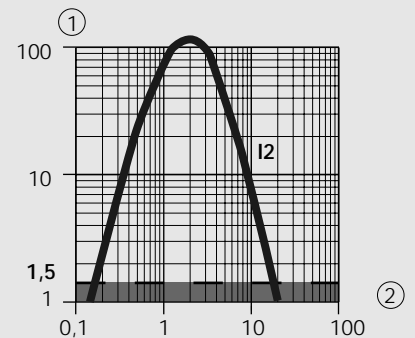

Typical excess gain curve
(with retroreflector OZR 001)

- ① Gain factor
- ② Range in (m)

Wiring diagram

DC version

NPN output

PNP output

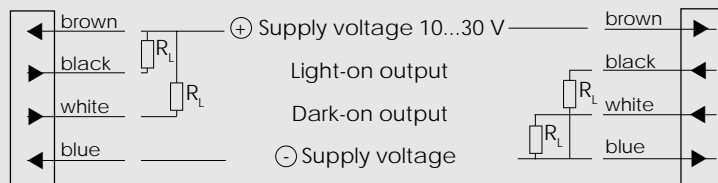

Connector M12	Wire color	Connection for test input	
1	brown	Supply+	Light-on output: Output energized when no object is present.
2	white	Test input	
3	blue	Supply -	Dark-on output: Output energized when object is present.
4	black	Output	

AC/DC version

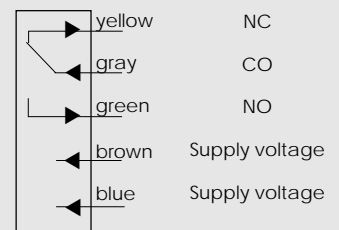

! No protective isolation!