

# Fiber optic sensors OPG for glass fiber optics and OPK for plastic fiber optics



- Light reserve warning indicator
- Dual transistor outputs, NPN or PNP
- Short-circuit protection, reverse polarity protection, and power-up output suppression
- Test input (option)
- Versions with up to 5000 Hz switching frequency available
- Connections: Cable, 2 meter  
Connector, M12  
Connector, M8 (option)  
Connector, Torson (option)
- EMC tested according to IEC 801 and EN 50081-1/EN 50082-2



## Product designation <sup>1)</sup>

Output

Connection

Range adjustment

## Optical data <sup>2)</sup>

Range

Emitter

## Electrical data <sup>2)</sup>

Supply voltage  $U_s$

Allowable ripple

Current consumption (without load)

Max. load current  $I_L$

Residual voltage

Max. switching frequency

## Environmental data

Sealing

Temperature  $T_A$   
(operating and storage)

Weight

OPG 1NA 100 I1	OPG 1NA 400 I1	OPG 1PA 100 I1	OPG 1PA 400 I1	OPK 1NA 100 R1	OPK 1NA 400 R1	OPK 1PA 100 R1	OPK 1PA 400 R1
NPN (light-/dark-on)		PNP (light-/dark-on)		NPN (light-/dark-on)		PNP (light-/dark-on)	
Cable 2 m	Connector M12	Cable 2 m	Connector M12	Cable 2 m	Connector M12	Cable 2 m	Connector M12
Yes							
depends on the selected fiber optic cable							
Infrared LED, 880 nm, pulsed				Visible-red LED, 660 nm, pulsed			
10...30 VDC							
+/- 10% of $U_s$							
< 15 mA							
200 mA							
< 1,6 V							
1000 Hz							
IP 65				IP 50			
-25...+65 °C							
ca. 100 g	ca. 35 g	ca. 100 g	ca. 35 g	ca. 100 g	ca. 35 g	ca. 100 g	ca. 35 g

## Option <sup>1)</sup>

Test input: emitter on

emitter off

+ $U_s$ or open			
< 1,5 V	< $U_s$ - 8 V	< 1,5 V	< $U_s$ - 8 V

1) For product designation of sensors with options see designation code on page 117.

2) When not otherwise noted, all technical data at  $T_A = 25^\circ\text{C}$  and  $U_s = 24\text{V}$ .

10...30 VDC

NPN / PNP  
light-on and  
dark-on output

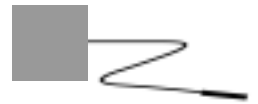

OPG, OPK

Dimensions (55 mm x 38 mm x 15 mm)

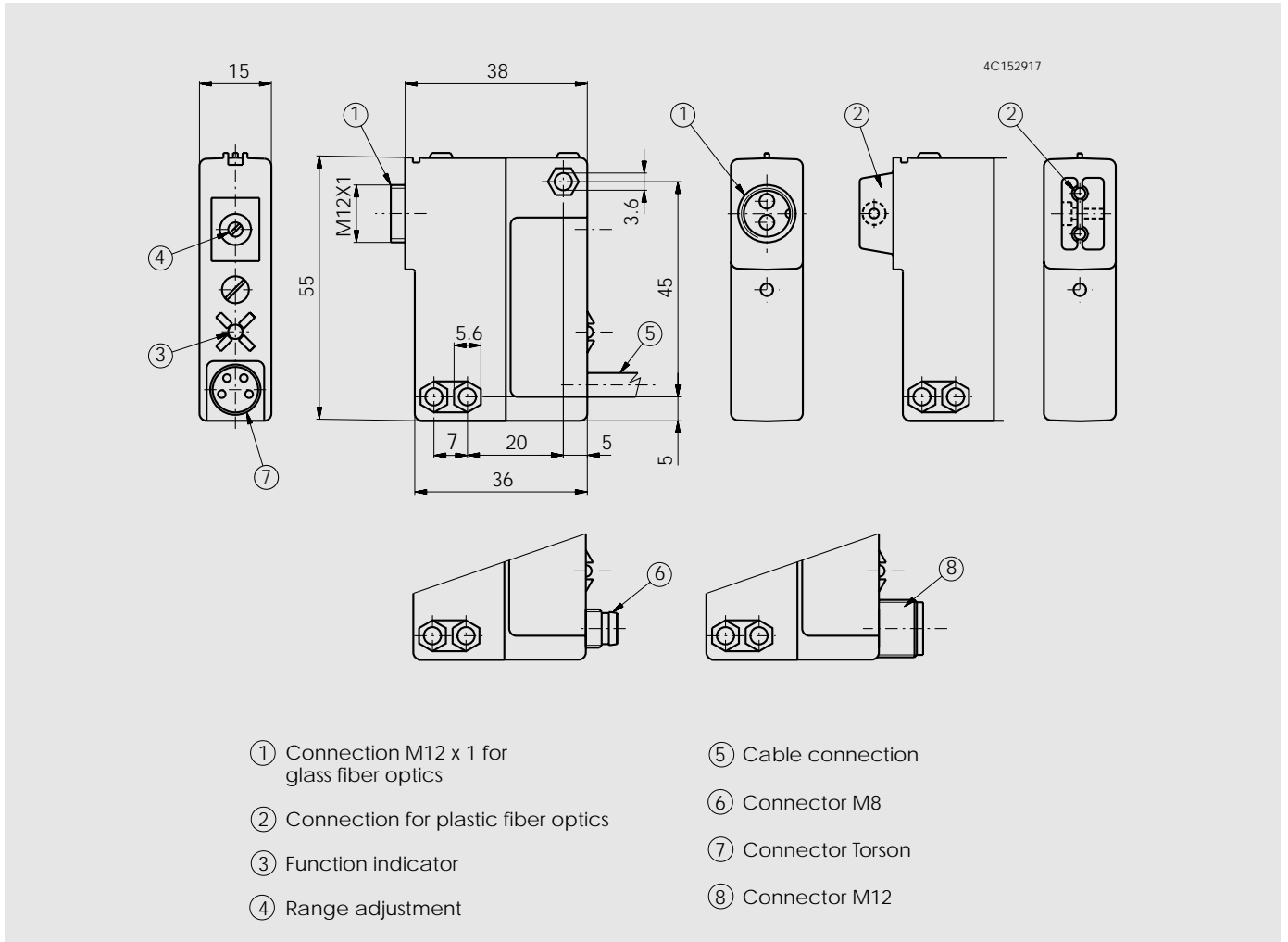

Wiring diagram

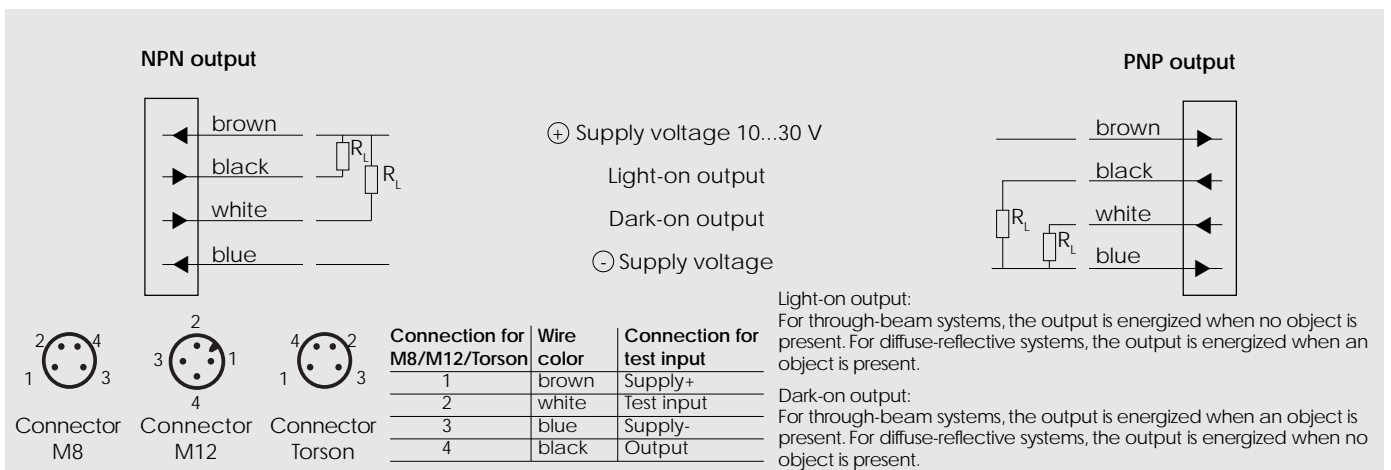

Dimensions

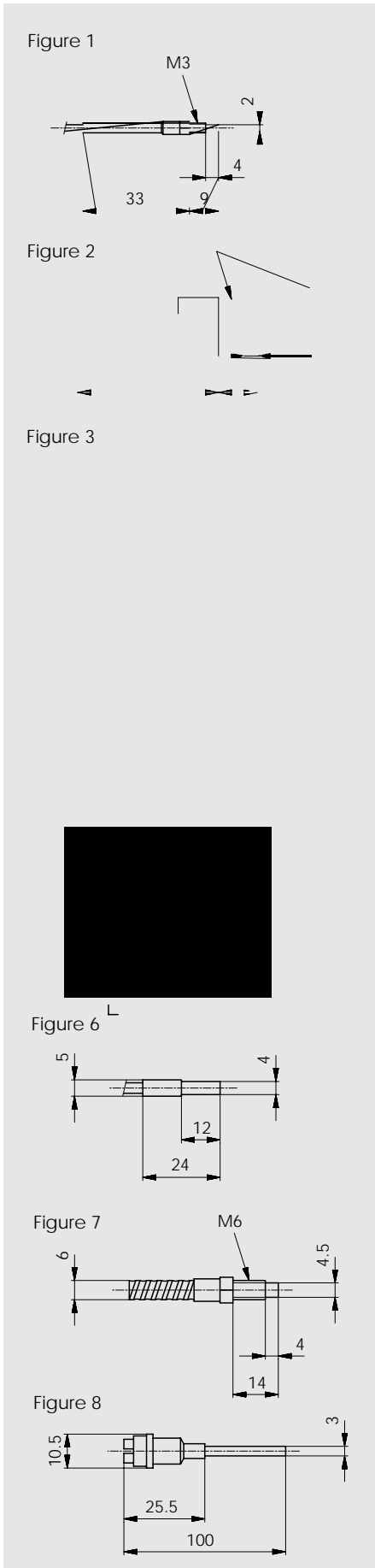

Through-beam

Fig.	Sensing head	Sheathing material	Cross section	Length	Range	Product designation
2	Threaded M4	Plastic (-25...+80 °C)	2 x 4 mm <sup>2</sup>	50 cm	500 mm	OZL 116 B 252
5	Ferruled 3 mm	Plastic (-25...+80 °C)	2 x 1 mm <sup>2</sup>	50 cm	200 mm	OZL 112 B 241
6	Ferruled 4 mm	Plastic (-25...+80 °C)	2 x 4 mm <sup>2</sup>	50 cm	500 mm	OZL 116 B 242
6	Ferruled 4 mm	Metal (-25...+250 °C)	2 x 4 mm <sup>2</sup>	50 cm	500 mm	OZL 216 B 242

Diffuse-reflective

Fig.	Sensing head	Sheathing material	Cross section	Length	Range <sup>1)</sup>	Product designation
1	Threaded M3	Plastic (-25...+80 °C)	2 x 0,5 mm <sup>2</sup>	25 cm	15 mm	OZL 141 B 151
2	Threaded M4	Plastic (-25...+80 °C)	2 x 1 mm <sup>2</sup>	25 cm	30 mm	OZL 142 B 152
3	Threaded M6	Plastic (-25...+80 °C)	2 x 4 mm <sup>2</sup>	25 cm	90 mm	OZL 146 B 154
4	Ferruled 1,5 mm	Plastic (-25...+80 °C)	2 x 0,5 mm <sup>2</sup>	25 cm	15 mm	OZL 141 B 140
7	Threaded M6	Metal (-25...+250 °C)	2 x 3 mm <sup>2</sup>	50 cm	80 mm	OZL 245 B 254
8	Ferruled 3 mm	Tube (-25...+120 °C)	2 x 1 mm <sup>2</sup>	10 cm	30 mm	OZL 042 B 001

1) Measured with Kodak card white, 10 x10 cm

Important mounting instructions:

Do not bend the glass fiber optic cables sharply. The bending radius may not be smaller than three times the sheathing diameter. Do not subject the fiber optic cables to mechanical forces (i.e. pulling, pressure, or twisting). The light emitting surfaces must also be protected from mechanical damage.

These glass fiber optic cables are only for use with fiber optic sensors OPG.

# Plastic fiber optic cables for OPK

## Dimensions

Figure 1

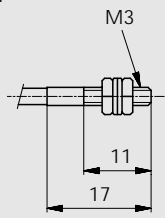

Figure 2

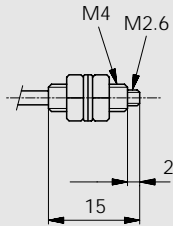

Figure 3

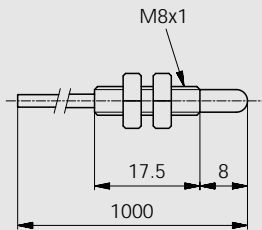

Figure 4

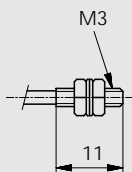

Figure 5

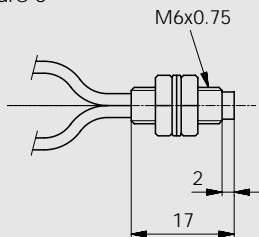
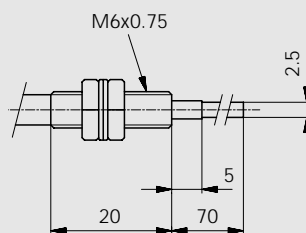
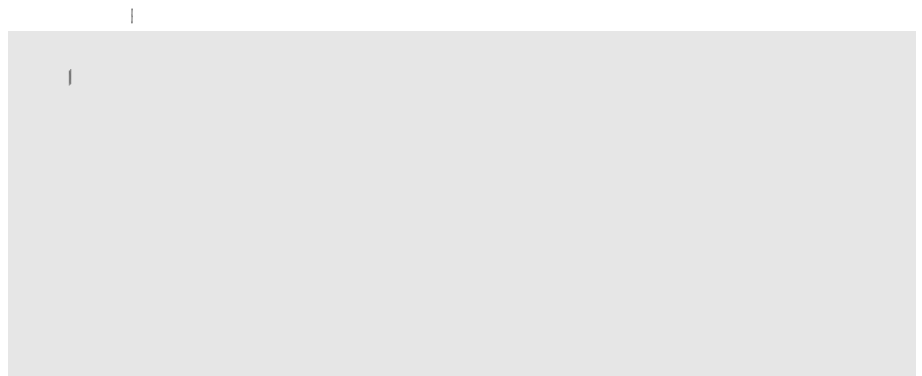

Figure 6



## Through-beam

Fig.	Sensing head	Sheathing material	Diameter	Length	Range	Product designation
1	Threaded M3	Plastic (-30...+70 °C)	2 x 0,5 mm	1 m	40 mm	OZL 511 D 351
2	Threaded M4	Plastic (-30...+70 °C)	2 x 1 mm	1 m	100 mm	OZL 512 C 352
3	Threaded M8	Plastic (-30...+70 °C)	2 x 1 mm with lens	1 m	1500 mm	OZL 511 C 376



### Important mounting instructions:

Do not bend the plastic fiber optic cables sharply. The bending radius may not be smaller than 25 mm. Do not subject the fiber cables to mechanical forces (i.e. pulling, pressure, or twisting). The light emitting surfaces must also be protected from mechanical damage.

Plastic fiber optic cables with a fiber diameter of 1 mm may be easily cut to the desired length with an appropriate cutter.

These plastic fiber optic cables are only for use with fiber optic sensors OPK.