

type number key

LR 024 VDC

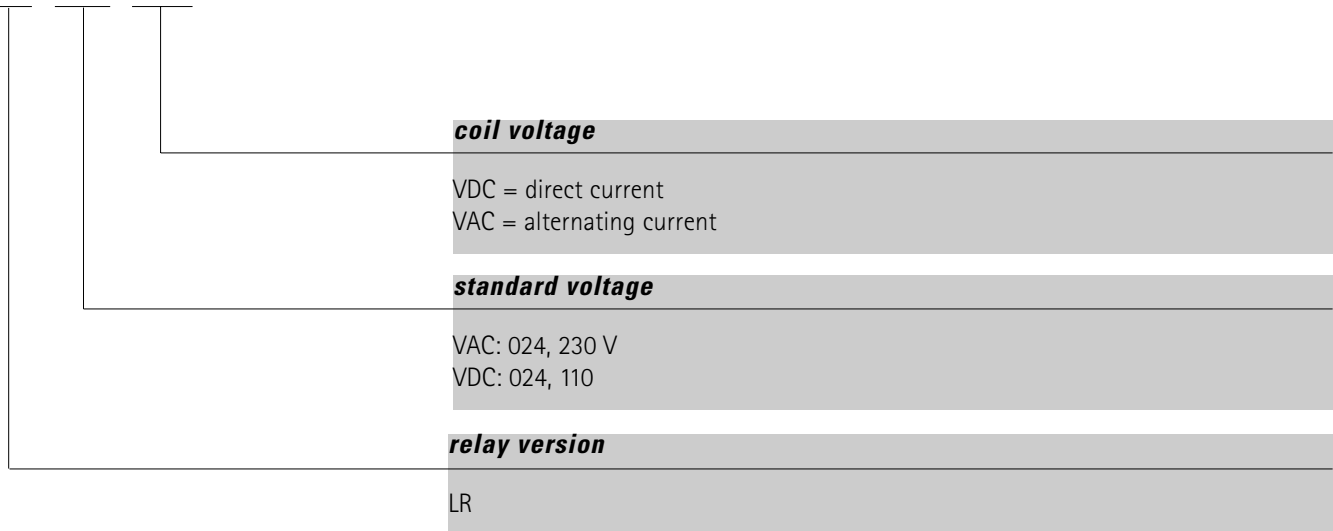

order sample

LR 230 VAC

- 3 normally open contacts
- coil voltage 230 VAC
- AMP connections
- DIN-rail installation



LR - power relay

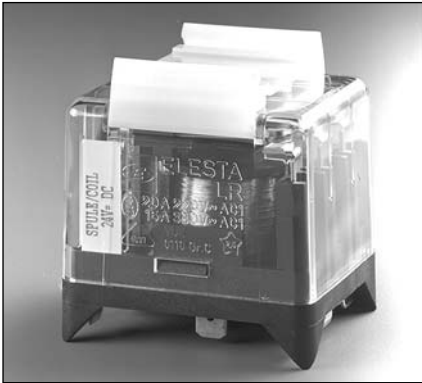

Power relays especially for switching high AC- loads.

order numbers

serial version	LR 220 VAC
	LR 24 VDC

contact specifications

(see data sheet for curves)

contact material	AgCdO
contact type	single contact
nominal switching capacity	250 VAC 20A AC1 5000 VA 400 VAC 15A AC1
electric life expectancy	app. 900'000 operations 250 VAC 20A AC1 (360 Schaltung/h)
inrush current max.	50A for 200 ms
switching current range	500mA to 20A
switching power range	8VA(W) to 5000VA

general data

max. switching frequency mechanical	15
mechanic life expectancy	20 Mio.
pull-in time	13 ms (VDC) /6-14 ms (VAC)
release time	2,5 ms (VDC) /3-12 ms (VAC)
bounce time	2 ms (VDC) /3 - 8 ms (VAC)
shock resistance	AK: 10 g
test voltage, coil/contact	2'500 V _{eff}
test voltage, open contact	2'500 V _{eff}
insulation resistance	>10 ¹² Ohm
weight	120 g
installation situation	any
ambient temperature max.	+60 °C

tests, instructions

certificates	CSA, VDE
insulation group	VDE 0110 / group C 250 VAC

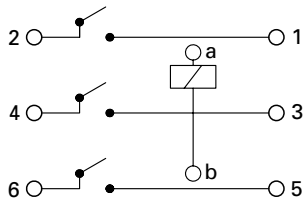
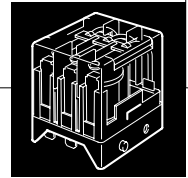

circuit diagram

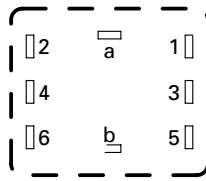

AMP connection side

dimensions

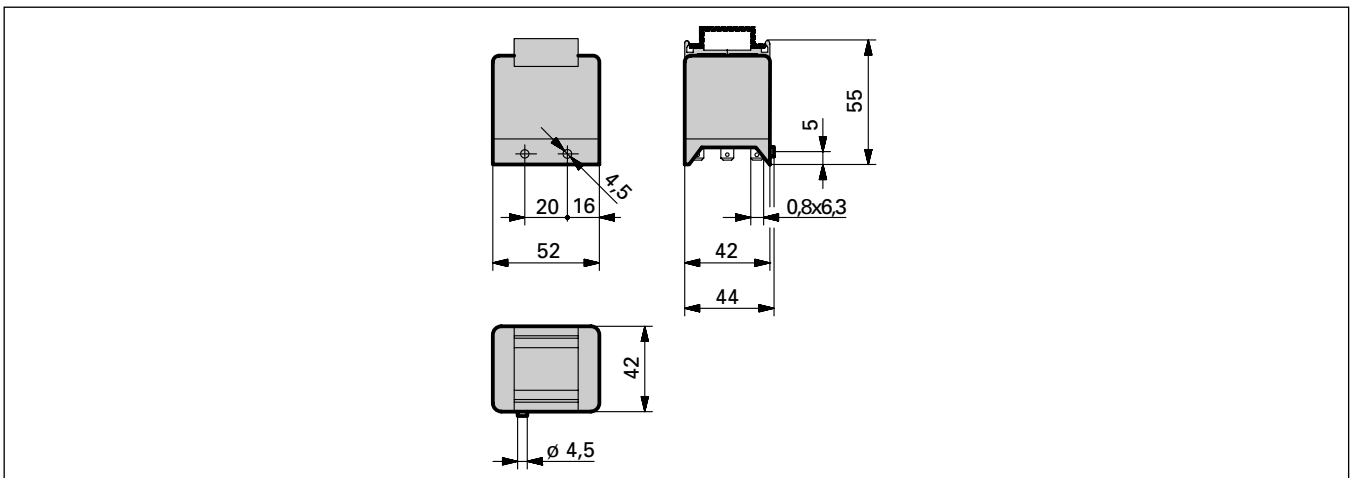

coil specifications

standard coils for direct current (other voltages on enquiry)

rated voltage VDC	pull-in voltage at 20 °C	reset voltage at 20 °C	nominal current mA	resistance Ohm at 20 °C	tolerance %
12	9	≥ 0,6	114	105	+/-10
24	18	≥ 1,2	58,5	410	+/-10
48	36	≥ 2,4	30,0	1'600	+/-10
110	82,5	≥ 5,5	13,8	8'000	+/-10

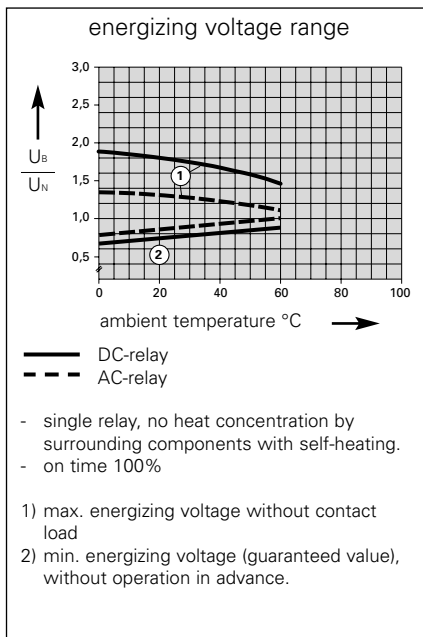

standard coils for alternated current (other voltages on enquiry)

VAC					
12	10,2	≥ 0,6	260	10	+/-10
24	20,4	≥ 1,2	130	40	+/-10
48	40,8	≥ 2,4	60	180	+/-10
110	93,5	≥ 5,5	29	950	+/-10
220	187	≥ 11	14	3'900	+/-10



LR - contact specifications

AgCdO

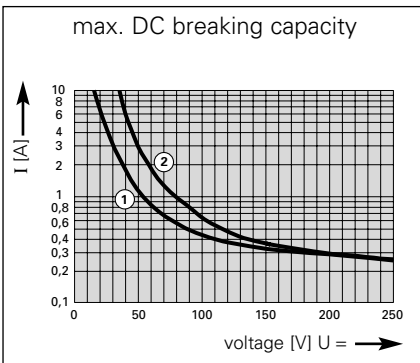

- 1 inductive load $L/R = 40$ ms
- 2 resistive load

data valid for relay	LR
contact material	AgCdO
contact type	single contact
nominal switching capacity	250VAC 20A AC1 5000VA 400VAC 15A AC1
electric life expectancy	app. 900'000 operations 250 VAC 20A AC1 (360 Schaltung/h)
inrush current max.	50A for 200 ms
switching current range	500mA to 20A
switching power range	8VA(W) to 5000VA(W)

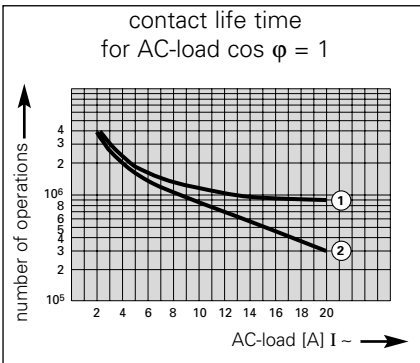

- 1: for 220 VAC (1-phase)
 - $I < 10$ A, max. 360 operations/h
 - $I > 10$ A, max. 180 operations/h
- 2: for 3 x 380 VAC (3-phase, star- or triangle circuit)
 - $I < 10$ A, max. 360 operations/h
 - $I > 10$ A, max. 180 operations/h

