



SGR-PCB RELAYS 441

No. of contacts: **1 NO**
 Rated current: **10 A**
 Inrush current: **20 A**

Order description

SGR 441 ...VDC

Contact data

Contact material	AgCdO
Type of contact	Single contact
Rated switching capacity	250 VAC 10A AC1 2500 VA
Max. switching voltage	400 VAC
Electrical life	approx. 100.000 operations 250 VAC 10 A
Contact resistance	< 50 mΩ

Coil data

Nominal voltages	3-5-6-9-12-18-24-36-48-60-110 VDC
Pick-up voltage	approx. 0,7 x Nominal voltage (at 20 °C)
Power consumption	typically 250 mW

Options

Contact material AgSnO₂ / AgNi / ...+AU
 SGR 441 ...VDC ASO
 SGR 441 ...VDC AN
 SGR 441 ...VDC ...+AU
 Sealed IP 67
 SGR 441V ...VDC ...
 High temperature model T=125°C
 SGR 441C ...VDC

General data

Mechanical life	30 x 10 ⁶ Operations
Max. switching frequency	450 Operations/h
Operate time	typically 8 ms
Release time	typically 5 ms
Bounce time	typically 3 ms
Vibration resistance	10 g (10-55 Hz)
Test voltage coil-contact	4.000 V _{eff}
Test voltage contact open	1.000 V _{eff}
Weight	11,5 g
Ambient temperature	-40°C - +85°C (125°C)
Temperature of soldering bath	270°C / 5 s
Protection category	IP 40

Accessories

PCB mounting socket
 ZGR 003
 Socket with screw terminals
 ZGE 006

Tests, regulations

Approvals	on request
Insulation group	C/250
Creeping and leakage distance	10 mm

Diagram

View from above

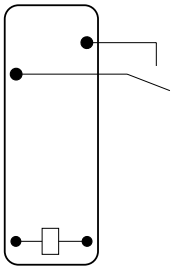

Dimensions drawing (mm)

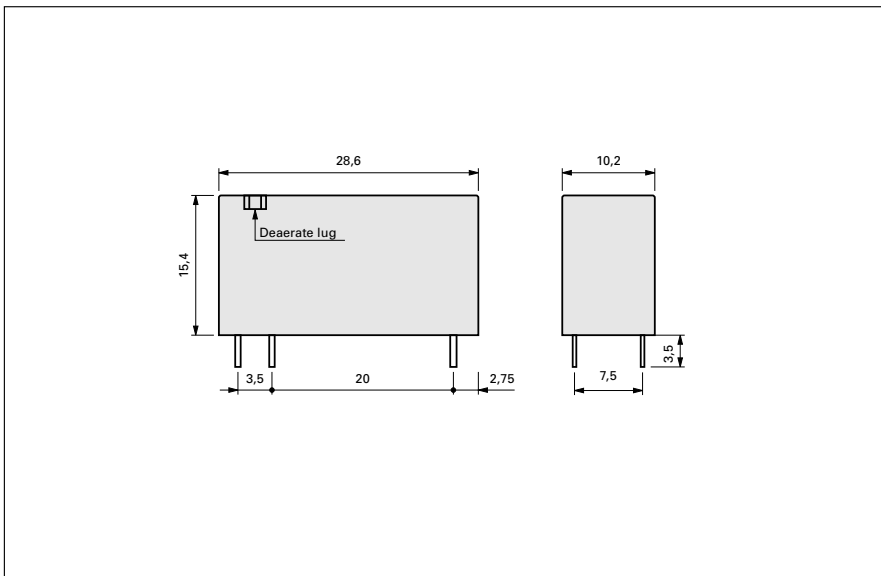

Drilling pattern (mm)

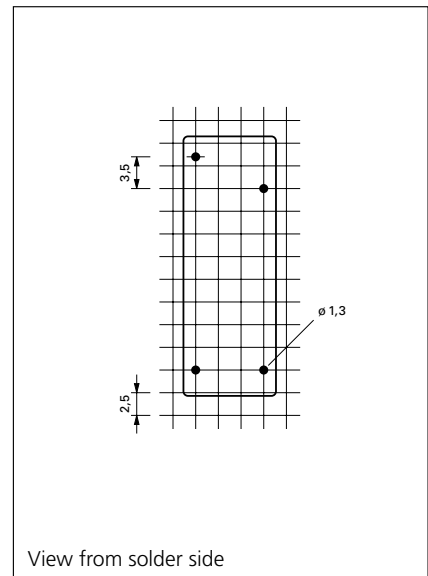

View from solder side

Coil data

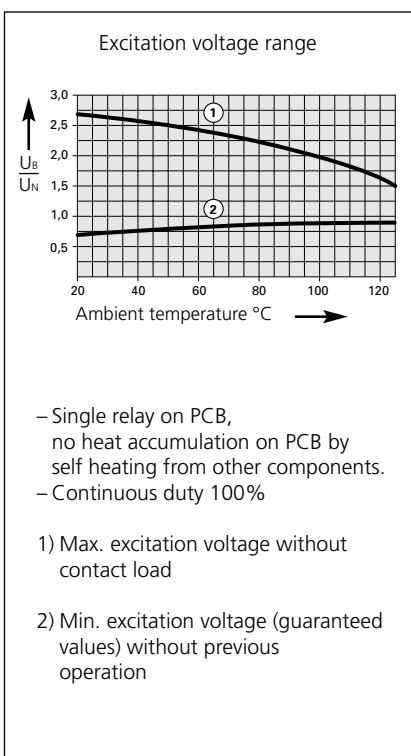

Standard coil for direct current (other voltages on request)

Nominal voltage VDC	Min. pick-up voltage at 20°C	Drop-out voltage at 20°C	Nominal current mA	Resistance Ohm at 20°C	Tolerance %
3	2,2	0,3	73,17	41	10
5	3,5	0,5	45,45	110	10
6	4,2	0,6	40,00	150	10
9	6,5	0,9	25,00	360	10
12	8,4	1,2	18,18	660	10
18	13,0	1,8	12,86	1.400	15
24	16,8	2,4	10,91	2.200	15
36	25,2	3,6	7,74	4.650	15
48	33,6	4,8	6,00	8.000	15
60	42,0	6,0	4,29	14.000	15
110	77,0	11,0	4,07	27.000	15